

REPAIR PARTS

P O BOX 71
1909 WEST MAIN STREET
800-334-3388
FAX 252-792-4913

www.reddickequipment.com

2020

We reserve the right to change prices at any time

ALPHABETICAL TABLE OF CONTENTS

DIAPHRAGM CHECK VALVES.....13

DITCHERS.....48,50-51

CLUTCH.....49

HAND GUNS.....1 - 2

HUB ASSEMBLIES.....47

PUMPS: ACE.....36-40

BANJO.....41-42

HYPRO.....17- 21,35

JOHN BLUE.....22-23

SHURFLO.....32

UDOR.....24-34

QJ360 MULTIPLE NOZZLE.....13

MONITOR

JOHN BLUE.....15-16

WILGER.....14

STRAINERS.....11-12

SPRAYING SYSTEMS

BANJO

HYPRO

VALVES: BANJO BALL VALVE.....7

RAVEN ELECTRIC CONTROL.....6

SPRAYING SYSTEMS ELECTRICAL.....8 - 10

PRESSURE RELIEF.....5

SPRAYING SYSTEMS SOLENOID, TEE AND DIRECTO.....3 - 4

YETTER.....43-46

43H BRASS AND 43LA-AL ALUMINUM HANDGUN

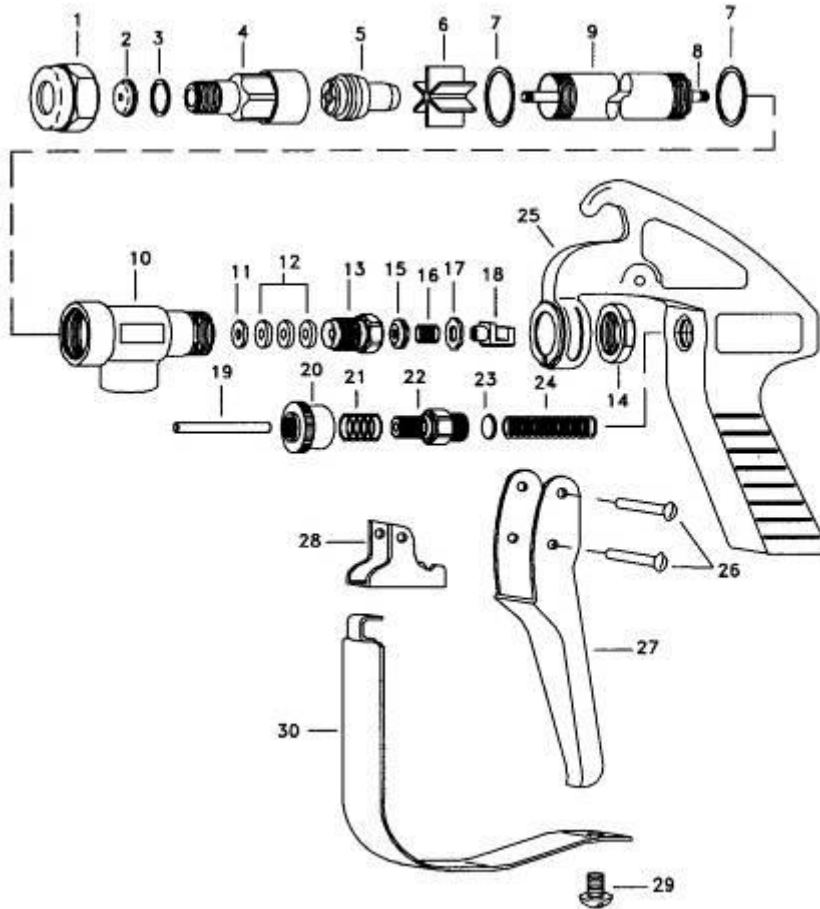

PARTS ALSO AVAILABLE FOR 43L AND 43L-AL HANDGUN

ITEM	BRASS PART NO.	ALUM PART NO.	DESCRIPTION	BRASS PRICE	ALUM PRICE
1	CP1325	CP1325-AL	CAP	1.65	1.57
2	D-**	D-**	ORIFICE DISC, HARDENED SS SPECIFY ORIFICE DISC SIZE (D6 STANDARD)	1.79	1.79
*3	CP4743-NY	CP4743-NY	GASKET, NYLON	1.87	1.87
4	CP10566	CP10566-AL	NOZZLE HOUSING	22.12	21.31
*5	10565-1-NY	10565-1-NY-AL	SEAT PLUG, SEAT PLATE, WASHER & CORE SUB-ASSY	34.05	34.05
6	CP10571-2-NYB	CP10571-3-NYB	GUIDE VANE	9.73	10.06
7	CP45195-NYB	CP45196-NYB	GASKET (2 REQ'D), NYLON BLACK	1.88	1.88
8	CP19238-416SS	CP19238-416SS	STEM, TYPE 416 SS(AA43H)	28.02	28.02
	CP19239-416SS	CP19239-416SS	STEM, TYPE 416 SS(AA43LA)	21.46	21.46
9	CP6604	CP6604-AL	TUBING(AA43H)	45.47	45.47
	CP6871	CP6871-AL	TUBING(AA43LA)	20.91	20.91
10	CP6492	CP6492-AL	INLET BODY	50.42	35.50
*11	CP6601-302SS	CP6601-302SS	PACKING WASHER, TYPE 302 SS	4.85	4.85
*12	CP6602-LEA	CP6602-LEA	PACKING, LEATHER (3 REQ'D) STANDARD	4.21	4.21
	CP6602-TEF	CP6602-TEF	PACKING, TEFLON (3 REQ'D) OPTIONAL	10.61	10.61
13	CP19237	CP19237-AL	PACKING SCREW	6.10	6.10
14	CP6599-NP	CP6599-NP	LOCKNUT	4.12	4.12
15	CP9641-INP	CP9641-INP	STEM NUT, STEEL, NICKEL PLATED	6.68	6.68
16	CP6595-SS	CP6595-SS	TRIGGER STOP SPRING, SS	3.62	3.62
17	CP7991-SS	CP7991-SS	WASHER, STAINLESS STEEL	1.32	1.32
18	CP6597-INP	CP6597-INP	TRIGGER GUIDE, STEEL, NICKEL PLATED	18.95	18.95
19	CP6591-SS	CP6591-SS	SPRING STUD, SS	4.32	4.32
20	CP6589-IZP	CP6589-IZP	STOP ADJUSTMENT NUT, STEEL, ZINC PLATED	5.64	5.64
21	CP6594-SS	CP6594-SS	SPRING FOR STOP ADJUSTMENT NUT, SS	1.94	1.94
22	CP6588-IZP	CP6588-IZP	SPRING SCREW, STEEL, ZINC PLATED	5.95	5.95
23	CP6592-302SS	CP6592-302SS	SPRING GUIDE WASHER, TYPE 302 SS	3.02	3.02
24	CP6593-1-SS	CP6593-2-SS	MAIN SPRING, SS	6.10	6.10
25	CP14477-1-AL	CP14477-1-AL	HANDLE BODY, ALUMINUM	66.44	66.44
26	CP7623-IZP	CP7623-IZP	RIVET, STEEL, ZINC PLATED (2 REQ'D)	1.83	1.83
27	CP6509-INP	CP6509-INP	TRIGGER, STEEL, NICKEL PLATED	7.18	7.18
28	CP6510-INP	CP6510-INP	TRIGGER STOP, STEEL, NICKEL PLATED	6.31	6.31
29	CP11757-SS	CP11757-SS	SCREW, SS	4.95	4.95
30	CP13798-INP	CP13798-INP	TRIGGER GUARD, STEEL, NICKEL PLATED	12.81	12.81
	PK-AB43-KIT	PK-AB43-AL-KIT	SPARE PARTS KIT(INCLUDES * ITEMS)	46.78	46.78

JD9 HIGH PRESSURE SPRAY GUN

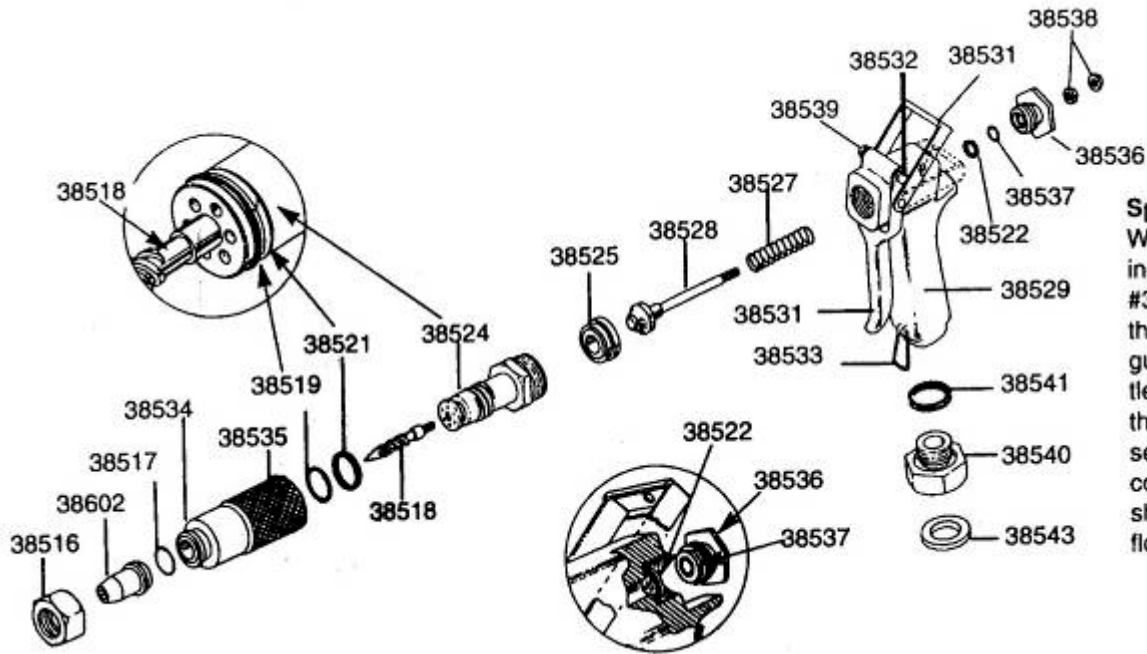

Special Note:
When tightening the two #38538 Nuts at the rear of the gun, allow a little slack so that the valve will seat properly, completely shutting off the flow.

PART NO.	DESCRIPTION	PRICE
38516	CAP	14.49
38517	O'RING	2.25
38518	WHIRLER	37.67
38519	O'RING	3.44
38521	BACK UP RING	2.77
38522	GLAND PACKING	2.57
38524	ADJUSTER BODY	81.83
38525	TEFLON VALVE SEAT	22.88
38527	VALVE SPRING	13.25
38528	SS VALVE	66.06
38529	GRIP	88.18
38531	TRIGGER ASSEMBLY	41.99
38532	O'RING	10.73
38533	STOPPER CLIP	1.62
38534	ADJUSTER NUT(BARREL)	83.23
38535	SCREW FOR ADJUSTER NUT	1.08
38536	GLAND	22.23
38537	O'RING	6.17
38538	NUT	1.08
38539	LOCKING NUT	5.81
38540	3/4" GARDEN HOSE COUPLING	38.41
38541	SPECIAL PACKING GASKET	3.56
38543	GARDEN HOSE WASHER	2.77
38602	NOZZLE TIP & RETAINER	22.91
*38510	REPAIR KIT	19.58
38511	REPAIR KIT W/38525	40.46
38512	TIP ADAPTER	26.71

*38510 REPAIR KIT INCLUDES ONE OF EACH 38517, 38519, 38521, 38522 AND 38537

NOZZLE TIPS - APPROX. FLOW RATE		
PART NO.	DESCRIPTION	PRICE
38602	LARGE STANDARD(3-8 GPM)	22.91
38603	EXTRA LARGE(10-19 GPM)	22.91
38604	MEDIUM(2-5 GPM)	22.91
38605	SMALL(1-3 GPM)	22.91
38606	EXTRA SMALL(0.3-1 GPM)	22.91
38633	FLOODING-PLASTIC(4 GPM)	42.80
38634	FLOODING-PLASTIC(2 GPM)	42.80
38635	FLOODING-PLASTIC(5 GPM)	42.80
38636	FLOODING-PLASTIC B(2 GPM)	42.80
38637	FLOODING-PLASTIC(1 GPM)	42.80

TIPS FOR 201-RF ROOTFEEDER		
PART NO.	DESCRIPTION	PRICE
38917	TIP-2 HOLE	95.83
38901	TIP-4 HOLE	106.83

A144A SOLENOID DIRECTOVALVE

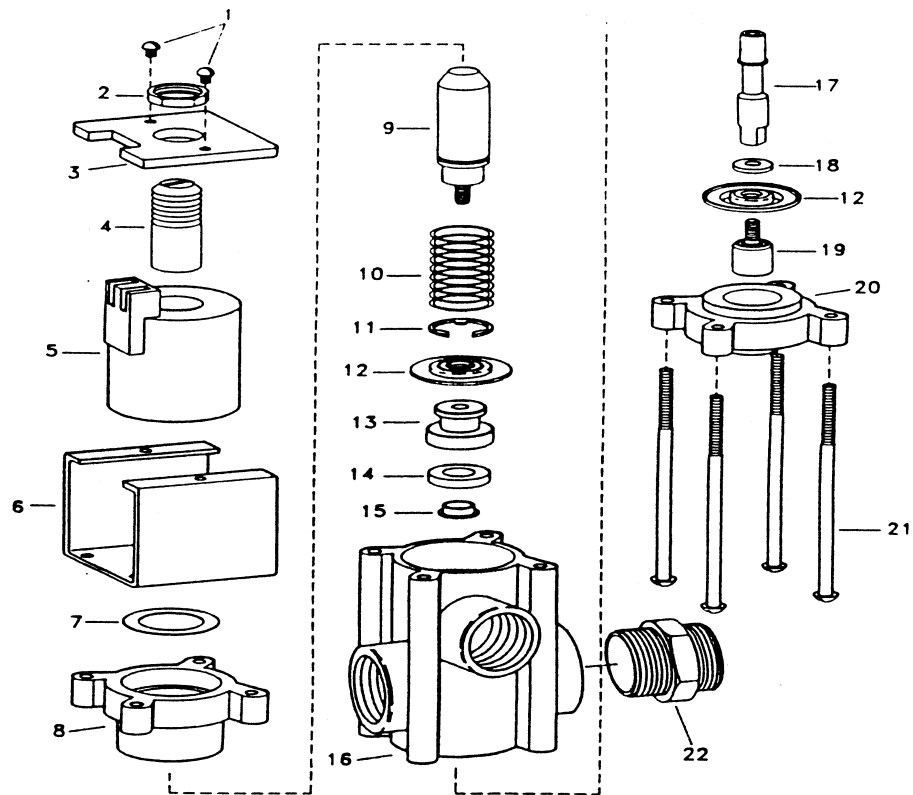

ITEM	PART NO.	DESCRIPTION	PRICE
4	CP15161-IENP	ARMATURE STOP, STEEL-ELECTROLESS NICKEL PLATED	13.38
5	CP15163-NYB	COIL ASSEMBLY, NYLON ENCAPSULATED (BLACK)	61.80
9	CP15170-IENP	ARMATURE, STEEL-ELECTROLESS NICKEL PLATED	24.67
*10**	CP15167-302SS	SPRING, TYPE 302 STAINLESS STEEL	6.56
11	CP14813-1-IENP	RETAINING RING, STEEL, NICKEL PLATED	2.49
*12	CP36101-EPR	DIAPHRAGM, EPDM RUBBER (STANDARD)(2 REQUIRED)	8.76
**	CP36101-VI	DIAPHRAGM, VITON (OPTIONAL) (2 REQUIRED)	19.73
*14	CP14802-EPR	SEAT WASHER, EPDM RUBBER (STANDARD)	6.77
**	CP14802-VI	SEAT WASHER, VITON (OPTIONAL)	23.79
16	CP14801-PP	BODY, POLYPROPYLENE (BLACK)	17.73
	PK-AB144A-1-KIT	SPARE PARTS KIT (INCLUDES * ITEMS)	33.53
	PK-AB144A-1-VI	SPARE PARTS KIT (INCLUDES ** ITEMS)	50.16

AA17L TEEVALVE

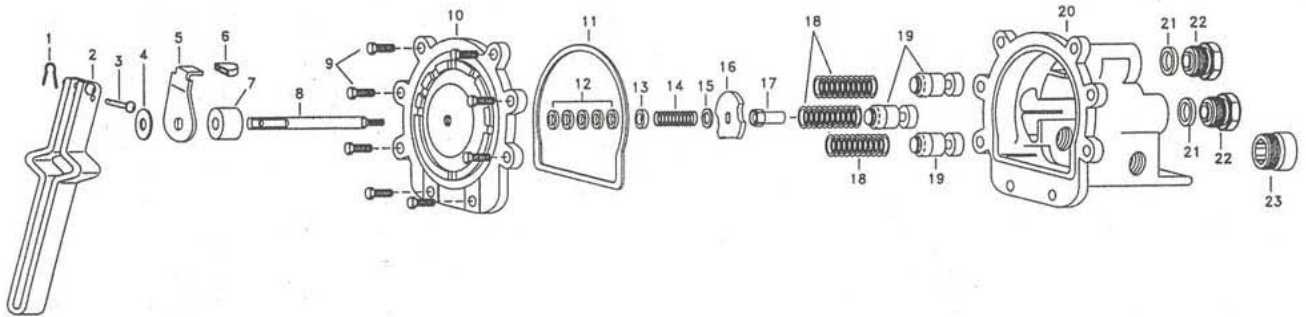

ITEM	PART NO.	DESCRIPTION	PRICE
*1	CP8012-1/2-SS	1/16" X 1/2" COTTER PIN, SS	1.88
2	CP6849-1-IZP	HANDLE, STEEL-ZINC PLATED	11.04
*3	CP7206-IZP	RIVET, STEEL-ZINC PLATED	6.58
*4	CP6976-IZP	HANDLE WASHER SPRING, STEEL-ZINC PLATED	4.71
5	CP12128-IZP	SELECTOR SHIELD, STEEL-ZINC PLATED	7.30
*6	CP12127-CE	SELECTOR SHIELD TIP, CELCON	4.85
*9	CP20607-IZP	SCREWS, STEEL-ZINC PLATED (8 REQD)	2.71
10	CP12126-AL	COVER PLATE, ALUM	60.87
*11	CP6975-BU	GASKET, BUNA-N	10.51
*12	CP5809-LEA	PACKING, THERMO-LEATHER (5 REQD)	1.88
18	CP6959-SS	VALVE SPRING, SS (3 REQ'D)	3.95
19	CP6956-CE	VALVE STEM, CELCON (3 REQD)	4.87
*21	CP6958-POL	SEAT PLATE, POLYETHYLENE (3 REQD)	8.06
22	CP7902-AL	OUTLET ADAPTERS, ALUMINUM (3 REQD)	11.83
	PK-AB17-KIT	SPARE PARTS KIT (INCLUDES *ITEMS)	43.29

AA6B DIRECTOVALVE

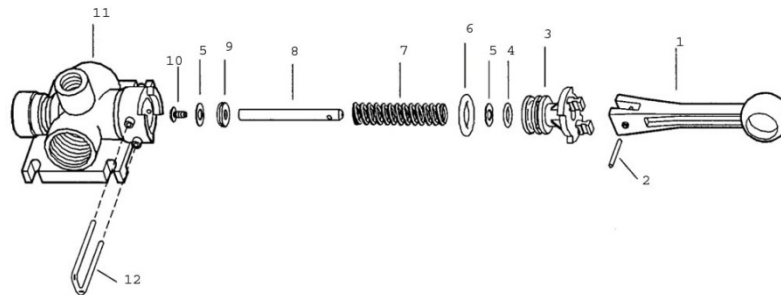

ITEM	PART NO.	DESCRIPTION	PRICE
1	CP36301-NY	HANDLE, NYLON GRAY	6.77
*4	CP7717-2/108-VI	O'RING VITON	6.09
5	CP36307-PPB	WASHER, POLYPROPYLENE (BLACK) 2 REQ'D	2.24
*6	CP7717-2/209-VI	O'RING VITON	10.09
*9	CP38726-VI	GASKET, VITON AND STAINLESS STEEL	8.66
11	CP36303-PP	BODY, POLYPROPYLENE (BLACK)	19.84
*	PK-AB6B-KIT	PARTS KIT (INCLUDES ALL ITEMS MARKED WITH *)	25.78

23120-PP & 23120A-PP PRESSURE RELIEF VALVE

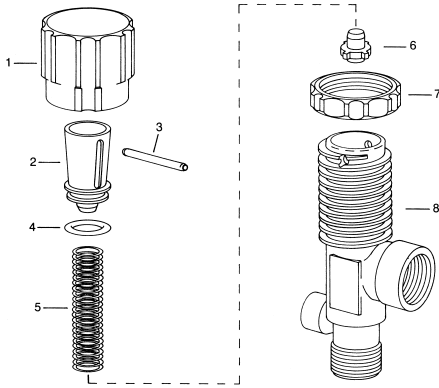

ITEM	PART NO.	DESCRIPTION	PRICE
1	CP23122A-NY	ADJUSTING CAP, NYLON	19.81
2	CP23124-PP	SPRING RETAINER, POLY	6.77
3	CP23126-302SS	RETAINING RING, TYPE 302SS	4.21
4	CP7717-15-EPR	O'RING, EPDM RUBBER(STD)	3.97
	CP7717-15-VI	O'RING, VITON (OPT)	7.88
5	CP23127-316SS	SPRING	17.81
6	CP23125-PP	GUIDE SEAT, POLY	5.24
7	CP23123-PP	LOCKRING, POLY	7.14
8	CP23128-PP	BODY, POLY (1/2)	25.06
	CP23121-PP	BODY, POLY (3/4)	25.06
9	8400-1/4-PPB	1/4" PIPE PLUG, POLY	1.79

6815 PRESSURE RELIEF VALVE

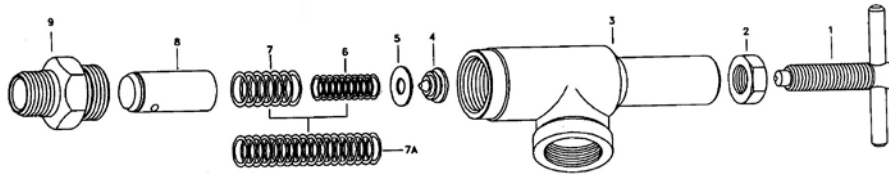

ITEM	PART NO.	DESCRIPTION	PRICE
1	CP5896	ADJUSTING SCREW ASSEMBLY, BRASS	7.18
2	CP5898	LOCKNUT, BRASS	2.21
3	CP6818-1/2	BODY, BRASS (FOR 6815-1/2--)	60.74
	CP6818-3/4	BODY, BRASS (FOR 6815-3/4--)	60.74
*4	CP6545	SPRING RETAINER, BRASS (FOR 6815-300)	2.21
	CP20138	SPRING RETAINER, BRASS (FOR 6815-700)	2.96
*5	CP5899-BU	GASKET, BUNA-N (STANDARD)	1.83
*6	CP6547-SS	INSIDE SPRING, SS (FOR 6815--300)	3.84
*7	CP6546-SS	OUTSIDE SPRING, SS (FOR 6815--300)	4.41
*7A	CP11714-PHSS	EXTRA DUTY 700 LB. SPRING, SS TO REPLACE ITEMS 6 & 7 (FOR 6815-700)	10.15
*8	CP6544	GUIDE SEAT, BRASS	9.12
	CP7756-BRHSS	GUIDE SEAT, BRASS WITH HARDENED S.S. SEAT	22.76
9	CP6789	INLET ADAPTER, BRASS (FOR 6815-1/2)	12.08
	CP7758-1/2BRHSS	INLET ADAPTER, BRASS WITH HARDENED SS (FOR 6815-1/2-HSS)	26.33
	CP7059	INLET ADAPTER, BRASS (FOR 6815-3/4--)	12.08
	CP7758-3/4BRHSS	INLET ADAPTER, BRASS WITH HARDENED SS (FOR 6815-3/4-HSS--)	26.33
	AB6815-700-KIT	SPARE PARTS KIT (INCLUDES *ITEMS)	17.99
	AB6815-HSS-300	SPARE PARTS KIT (INCLUDES *ITEMS)	25.00
	AB6815-HSS-700	SPARE PARTS KIT (INCLUDES *ITEMS)	29.51
	PK-AB6815-300	REPAIR KIT	19.29

RAVEN CONTROLS

SCS-11

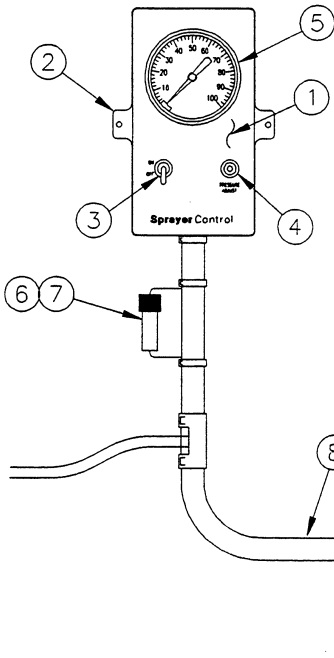

ITEM	PART NO.	DESCRIPTION	PRICE
1	107-0159-092	N/A	
2	106-0159-001	N/A	
3	412-2011-038	ON/OFF SWITCH	10.85
4	412-2011-041	PRESSURE ADJUST SWITCH	25.30
5	117-0159-007	PST GAUGE, FEMALE FITTING ASSY	44.00
6		N/A	
7	510-1003-001	N/A	
8	115-0159-005	N/A	
9	063-0159-001	3/4" VALVE ASSEMBLY	110.00
10	063-0172-126	1" VALVE ASSEMBLY	264.00
11	063-0171-895	1 1/2" VALVE ASSEMBLY	356.45
12	214-0001-001	TUBING LENGTH AS REQUIRED	1.27
	417-0001-004	GAUGE	28.60

SCS-203

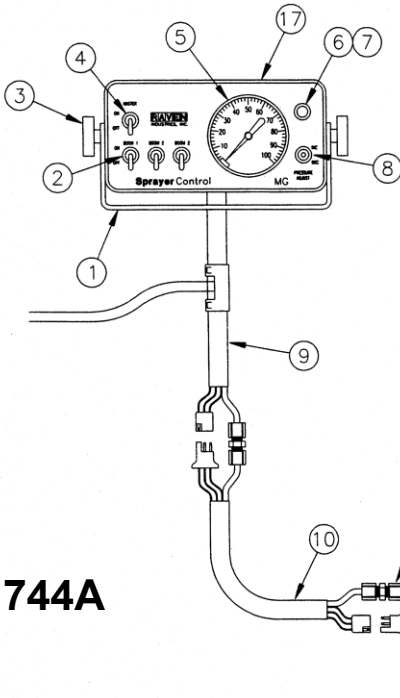

ITEM	PART NO.	DESCRIPTION	PRICE
1	107-0159-007	MOUNTING BRACKET	24.20
2	412-2011-038	BOOM SWITCH	10.85
3	309-1000-006	MOUNTING KNOB	2.48
4	412-2011-037	MASTER SWITCH	8.00
5	117-0159-006	PSI GAUGE, FEMALE FITTING ASSY	52.80
6	510-2001-003	FUSE HOLDER	18.70
7	510-1003-001	N/A	
8	412-2011-039	PRESSURE SWITCH	20.97
9	115-0159-010	CONSOLE CONTROL CABLE(8 FT)	70.40
10	107-0159-025	FLOW EXT. CABLE(12 FT)	99.00
11	115-0159-013	FLOW CONTROL CABLE(6 FT)	86.90
	115-0159-015	FLOW CONTROL CABLE(12 FT)	113.30
12	333-0001-008	UNION FITTING	8.25
13	214-0001-001	TUBING(LENGTH AS REQUIRED)	1.21
14	063-0159-001	3/4" VALVE ASSEMBLY	110.00
15	063-0172-126	1" VALVE ASSEMBLY	264.00
16	063-0171-895	1 1/2" VALVE ASSEMBLY	356.40
17	063-0159-203	SCS 200 SERIES CONSOLE	
18	417-0001-002	GAUGE ONLY	28.60
19	333-0001-004	GAUGE FITTING	6.11
20	333-0001-007	1/4" MALE TUBE FITTING	5.06

744A

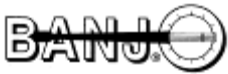

BOLTED POLYPROPYLENE BALL VALVES

V100FP - V125

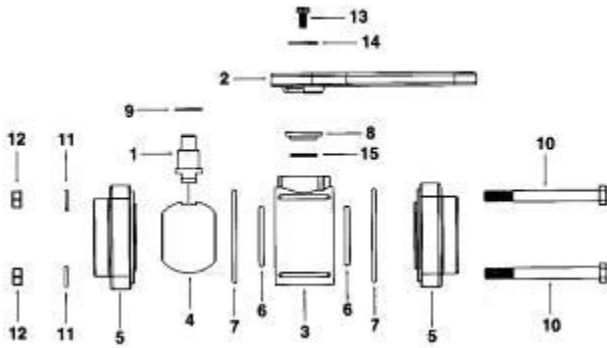

V050 - V075 - V100

ITEM	PART NO.	DESCRIPTION	PRICE
1	V07151A	STEM	4.48
2	V10153A	HANDLE	6.12
3	V07254	VALVE BODY	10.37
4	V07155	VALVE BALL	8.19
5	V07257	ENDPLATE 3/4"	11.48
	V07256	END PLATE 1"	11.48
6	V07258A	BALL SEAT	5.54
7	V07264E	VALVE BODY O'RING EPDM	5.54
8	V07159	UPPER STEM	2.72
10	V07017	BODY BOLT	1.42
11	V07018	1/4" SS LOCK WASHER	1.20
12	V07019	1/4" SS NUT	1.20
13	V10020A	#10 X 1 1/4" SS HWHSMS	1.30
NS	V07200	VALVE REPAIR KIT	26.12

NS-NOT SHOWN IN PICTURE

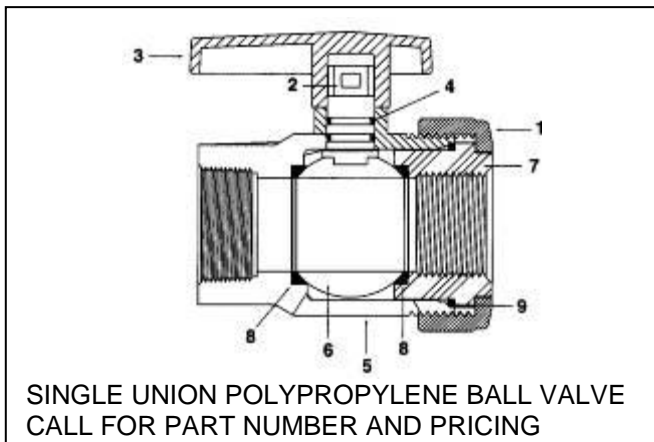

SINGLE UNION POLYPROPYLENE BALL VALVE
CALL FOR PART NUMBER AND PRICING

ITEM	PART NO.	DESCRIPTION	PRICE
1	V10151A	STEM	5.57
2	V10153A	HANDLE	6.12
3	V10254	VALVE BODY	10.37
*4	V10155	VALVE BALL 1" FP	9.29
5	V10257	END PLATE 1" FULL PORT	14.75
	V10256	END PLATE 1 1/4"	14.75
*6	V10258A	BALL SEAT	8.15
7	V10264	VALVE BODY O'RING FKM	8.98
*8	V10159	UPPER LOWER STEM BUSHING	3.05
10	V10117	5/16" X 3 1/2" SS BODY BOLT	1.92
11	V10118	5/16" SS LOCK WASHER	1.20
12	V10119	5/16" SS NUT	1.20
13	V10020A	#10 X 1 1/4" SS HWHSMS	1.30
NS	V10200	VALVE REPAIR KIT	31.24
NS	V10270	STRAIGHT MOUNTING BRT	39.84
NS	V10271	90 DEGREE MOUNTING BRT	11.42

V125FP - V150 - V200 - VA150 - VA200

ITEM	PART NO.	DESCRIPTION	PRICE
1	V20151M	STEM	10.37
2	V20152	HANDLE (ANGLE)	10.37
	V20153	HANDLE	10.37
*4	V20255A	VALVE BALL	15.85
5	V20256	END PLATE 2"	16.93
	V20257	END PLATE 1 1/2"	16.93
*6	V20258A	BALL SEAT	11.42
*10	V20264	VALVE BODY O'RING, VITON	11.42
*8	V20159	UPPER STEM BUSHING	4.46
*9	V20060	THRUST WASHER	2.50
11	V20018	3/8" SS LOCK WASHER	1.20
12	V20019	3/8" SS NUT	1.30
13	V20020A	1/4" X 1/2" SS HANDLE BOLT	7.84
14	V20021	SS HANDLE WASHER	1.10
*15	V20163	STEM O'RING FKM	3.16
NS	V20200	VALVE REPAIR KIT	46.90
NS	V25271	90 DEGREE MOUNTING BRT	22.30
NS	V25270	STRAIGHT MOUNTING BRT	19.03

344BEC ELECTRIC BALL VALVE

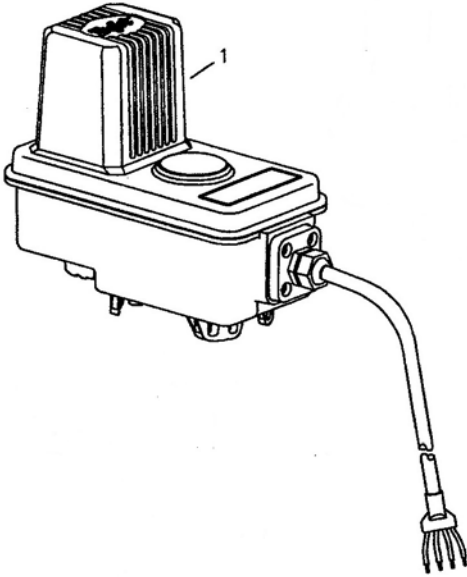

ITEM	PART NO.	DESCRIPTION	PRICE
1	50515-22CP05	MOTOR, 22-RPM	313.06
	50515-22CP05J	MOTOR, 22-RPM WITH ENDS	321.88
	50515-22CP05VX	MOTOR, 22 RPM WITH WEATHER PAC ENDS	330.67

440BEC ELECTRIC BALL VALVE MANIFOLD ASSEMBLY

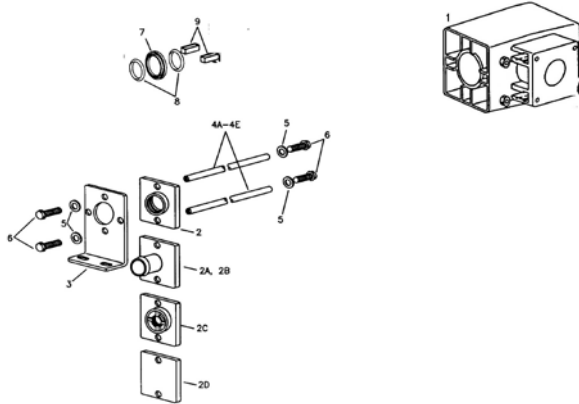

ITEM	PART NO	DESCRIPTION	QUANTITY REQUIRED					PRICE	
			440	441	442	443	444		445
1	CP39581-NYB	MANIFOLD BODY, NYLON							43.64
2	CP37548-PP	1" NPT FEMALE THREADED INLET,POLY		*	*	*	*	*	10.14
4C	CP39583-3-SS	STUD, STAINLESS STEEL				2			32.19
4D	CP39583-4-SS	STUD, STAINLESS STEEL					2		32.35
4E	CP39583-5-SS	STUD, STAINLESS STEEL						2	32.42
7	CP37159-PP	INNER CONNECTOR, POLY			1	2	3	4	11.01
8	CP7717-2/218-VI	O-RING, VITON		2	4	6	8	10	6.60
9	CP39769-PP	ALIGNMENT INSERT, POLY			2	4	6	8	2.09

*INLET CONNECTIONS, ITEMS 2A-2D, TO BE SPECIFIED WHEN MANIFOLD IS ORDERED.

430EC THREE WAY DIRECTOVALVE

ITEM #	PART #	DESCRIPTION	PRICE
1	58445	EC MOTOR 22-RPM	196.49
2	CP58436-302SS	FLAT WASHER, 302 SS	.95
3	CP7717-M4.8X1.8-VI	ORING VITON (2 REQD)	8.15
4	CP58435-SS	STEM, SS	30.84
5	CP58469-SS	E-CLIP RETAINING RING SS	.97
6	CP58450-302SS	MOTOR RETAINING CLIP SS	3.53
7	CP58431-PP	VALVE BODY, POLY	22.24
8	CP50507-304SS	MOUNTING PLATE SS	5.74
9	CP7717-2/115-VI	ORING VITON (2 REQD)	2.70
10	CP58434-TEF	SEAL TEFLON (2 REQD)	20.22
11	CP58433-SS	THREE WAY BALL, SS	57.70
12	CP58465-302SS	SCREW, SS (2 REQD)	3.14
13	CP7717-2/120-VI	ORING VITON (2 REQD)	6.60
14	CP58455-PP	BYPASS END CAP, POLY	5.05
15	CP7717-2/116-VI	ORING VITON	3.75
16	CP58457-304SS	BYPASS RETAINING CLIP, SS	5.60
18	CP7717-3-912-VI	ORING VITON	6.60
19	CP37166-1-302SS	REGULATED BYPASS BODY RETAINING CUP SS	2.86
20	CP58461-PP	REGULATED BYPASS PLUNDER, PP	3.40
21	CP7717-2-107-VI	ORING VITON	0.23
22	CP58462-PP	REGULATED BTPASS DIAL CELON	6.01
23	CP58463-NY	REGULATED BYPASS INDICATOR RING	5.92
24	CP58464-302SS	REGULATED BYPASS DIAL RETAINING CLIP SS	4.19
25	CP58468-5-SS	FIVE BANK MANIFOLD CONNECTING ROD	49.00
26	CP58555-SS	M8 SPLIT LOCK WASHER (2 REQD)	1.71
27	CP46074-302SS	M8X1.25 HEX NUT SS (2 REQD)	0.93
28	CP58437-PP	MALE INLET ADAPTER POLY	13.21
28A	CP98503-NYB	75 FLANGE MALE ADAPTER	13.55
29	CP58438-PP	FEMALE INLET ADAPTER, POLY	13.21
29A	CP98502-NYB	75 FLANGE FEMALE ADAPTER	13.55
30	CP7717-2-225-VI	ORING VITON, (2 REQD)	1.15

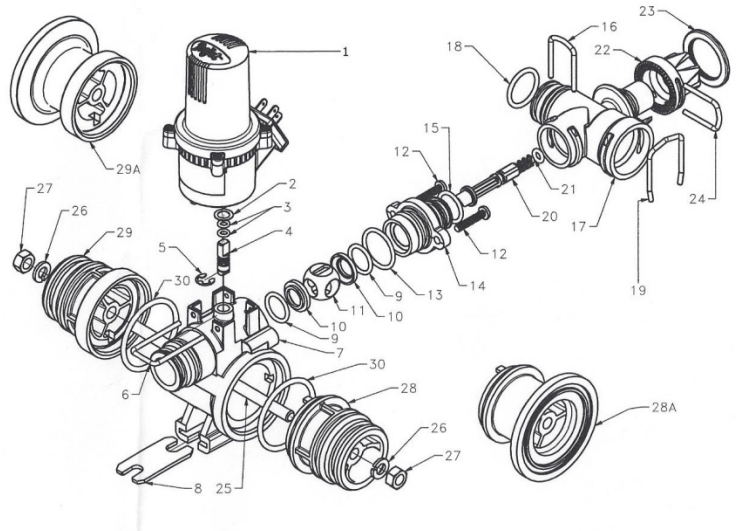

430EC FLOW BACK DIRECTOVALVE

ITEM#	PART#	DESCRIPTION	PRICE
20	CP58468-5-SS	FIVE BANK MANIFOLD CONNECTING ROD, SS	49.00
21	CP58555-SS	M8 SPLIT LOCK WASHER (2 REQD)	1.71
22	CP46074-302SS	M8X1.25 HEX NUT, SS (2 REQD)	0.93
23	CP58437-PP	MALE INLET ADAPTER, POLY	13.21
24	CP58438-PP	FEMALE INLET ADAPTER, POLY	13.21
25	CP7717-2-225-VI	ORING, VITON (2 REQD)	1.15

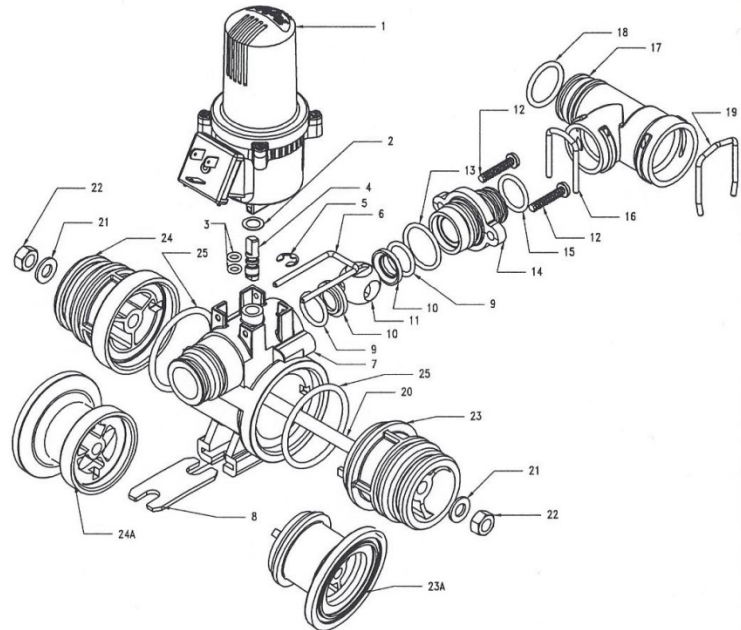

744E-CPT435MV – METER VALVE

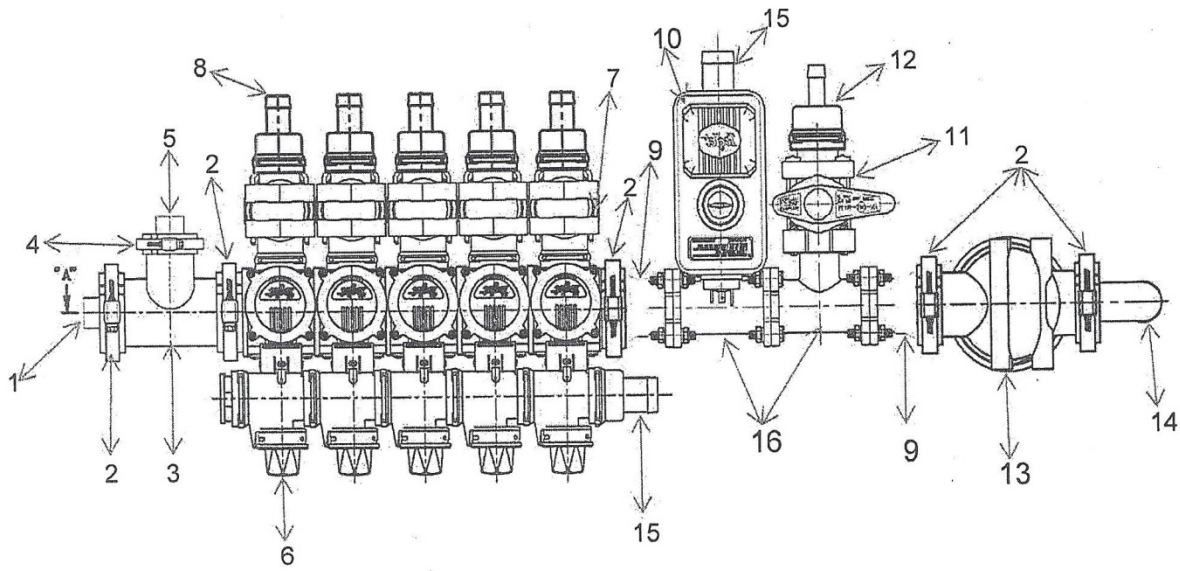

844E/RADION-CPT435FB – FLOW METER/FLOW BACK

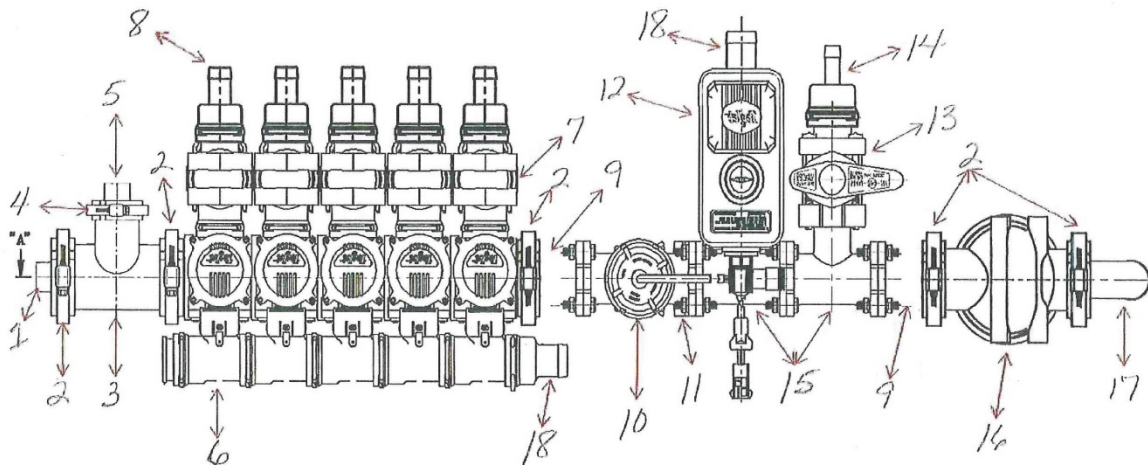

ITEM	DESCRIPTION	ITEM	DESCRIPTION	ITEM	DESCRIPTION
1	CP46127-1/4-PP	2	55245-75	3	CP46717-PP
4	55245-50	5	CP45508-1/4-PP	7	AA122ML-QC-PP-50
8	45529-3/4	9	CP98490-NYB		

THESE ARE COMMON PARTS ON BOTH METERS. PLEASE CALL FOR MORE INFORMATION.

STRAINERS



3350-0079A 1/4" ID & 1/2" OD

PART #	DESCRIPTION	PRICE
3351-0035	CAP	3.17
1700-0090	GASKET, EPDM	1.09
3800-0046	50 MESH SCREEN	3.00
3351-0036	BOWL, BLACK	2.94
3351-0020	BOWL, CLEAR	4.96

3350-0044 3/4" STRAINER

PART #	DESCRIPTION	PRICE
3351-0006	CAP	12.53
1700-0044	GASKET, BUNA	1.08
1700-0045	GASKET, VITON	3.23
3800-0029	20 MESH SCREEN	8.85
3800-0025	50 MESH SCREE	7.47
3800-0026	80 MESH SCREEN	12.00
3351-0005	BOWL	7.37

3350-0061 1" STRAINER

PART #	DESCRIPTION	PRICE
3351-0014	CAP	21.26
1700-0057	GASKET, BUNA	1.50
1700-0058	GASKET, VITON	4.50
3800-0040	20 MESH SCREEN	11.06
3800-0041	50 MESH SCREEN	11.06
3800-0042	80 MESH SCREEN	18.61
3351-0013	BOWL	16.08

3350-0075 1 1/4" STRAINER

PART #	DESCRIPTION	PRICE
3351-0016	CAP	25.35
1700-0057	GASKET, BUNA	1.50
1700-0058	GASKET, VITON	4.50
3800-0043	20 MESH SCREEN	11.06
3800-0044	50 MESH SCREEN	11.06
3800-0045	80 MESH SCREEN	21.05
3351-0013	BOWL	16.08

3350-0116 1 1/2" STRAINER

PART #	DESCRIPTION	PRICE
3351-0026	CAP	28.07
1700-0057	GASKET, BUNA	1.50
1700-0058	GASKET, VITON	4.50
3800-0065	20 MESH SCREEN	18.35
3800-0066	50 MESH SCREEN	16.20
3800-0067	80 MESH SCREEN	26.16
3351-0013	BOWL	16.08

TeeJet Poly Strainers AA122-1/2-PP & AA122-3/4-PP

PART #	DESCRIPTION	PRICE
CP23171-1/2-PP	CAP, POLY - 1/2"	9.84
CP23171-3/4-PP	CAP, POLY- 3/4"	
CP45102-3-SSPP	50 MESH SCREEN, RED	8.17
CP45102-4-SSPP	80 MESH SCREEN, BLUE	
CP45102-5-SSPP	100 MESH SCREEN, GREEN	
CP23173-EPR	GASKET, EPDM	5.62
CP23173-VI	GASKET, VITON	10.81
CP23172-PP	BOWL, POLY	8.69

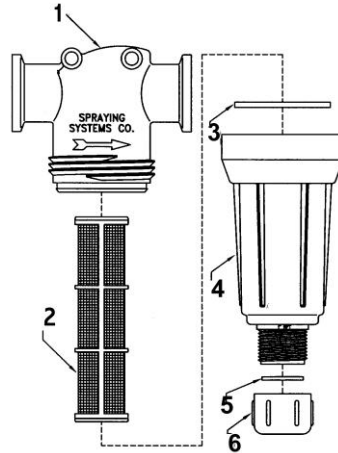

AA126ML

ITEM	PART #	DESCRIPTION	PRICE
1	CP50492-3/4-PP	HEAD, 3/4"	14.50
	CP50492-1-PP	HEAD 1"	
2	CP16903-1-SSPP	15 MESH SCREEN, GRAY	15.86
	CP16903-3-SSPP	30 MESH SCREEN, YELLOW	
	CP16903-4-SSPP	50 MESH SCREEN, RED	
	CP16903-5-SSPP	80 MESH SCREEN, BLUE	
	CP16903-6-SSPP	100 MESH SCREEN, GREEN	
	CP16903-7-SSPP	200 MESH SCREEN, ORANGE	
3	CP50494-EPR	GASKET, EPDM	2.66
	CP50494-VI	GASKET, VITON	6.74
4	CP50493-PP	BOWL, GRAY	14.31
5	CP63150-EPR	GASKET, EPDM	3.52
6	CP48655-PP	CAP, GRAY 3/4", 1/2", 1 1/4", 1 1/2"	5.21
1 1/4" & 1 1/2"			
1	CP63065-1-1/4PP	HEAD, 1 1/4"	29.57
	CP63066-1-1/2PP	HEAD, 1 1/2"	
2	CP15941-1-SSPP	16 MESH SCREEN, GRAY	22.33
	CP15941-2-SSPP	30 MESH SCREEN, YELLOW	
	CP15941-3-SSPP	50 MESH SCREEN, RED	
	CP15941-4-SSPP	80 MESH SCREEN, BLUE	
	CP15941-5-SSPP	100 MESH SCREEN, GREEN	
	CP15941-6-SSPP	120 MESH SCREEN, SS	
3	CP48656-EPR	GASKET, EPDM	5.37
	CP48656-VI	GASKET, VITON	11.19
4	CP48654-PP	BOWL	29.27
5	CP63150-EPR	GASKET, EPDM	3.52
	CP63150-VI	GASKET, VITON	8.97



POLYPROPYLENE "Y" STRAINERS LS-075, LS-100, LS-125, LS-150, LS-200

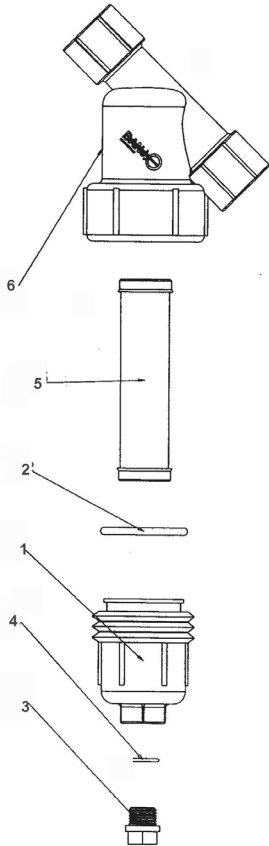

ITEM	PART NO.	DESCRIPTION	PRICE
1	LS075C1	END CAP (1/2" - 3/4")	11.48
	LS100C1	END CAP (1" - 1 1/4")	16.93
	LS150C	END CAP (1 1/2" - 2") NEW STYLE	29.46
2	LS075-G	GASKET (1/2" - 3/4" O'RING)	3.37
	LS075-GV	GASKET-FKM(VITON)	7.07
	LS100-G	GASKET (1" - 1 1/4" O'RING)	4.46
	LS100-GV	GASKET-FKM(VITON)	8.15
	LS150-G	GASKET (1 1/2" - 2") NEW STYLE O'RING THICKER	4.46
	LS150-GV	GASKET-FKM(VITON TYPE)	16.15
3	12723	1/4" DRAIN PLUG (1/2" - 3/4")	2.35
	12777	1/2" DRAIN PLUG (1" - 1 1/4")	3.28
	LSQ200-PL	1" DRAIN PLUG (1 1/2" - 2")	3.81
4	12724	EPDM O'RING FOR DRAIN PLUG (1/2" - 3/4")	1.08
	UV15163	EPDM O'RING FOR DRAIN PLUG (1" - 1 1/4")	1.20
	UV15163V	FKM(VITON) O'RING FOR DRAIN PLUG (1" - 1 1/4")	4.90
	LSQ200-R	EPDM O'RING FOR DRAIN PLUG (1 1/2" - 2")	1.20
	LSQ200-RV	FKM(VITON) O'RING FOR DRAIN PLUG(1 1/2" - 2")	1.92
5	LS720	20 MESH SCREEN (1/2" - 3/4")	28.80
	LS740	40 MESH SCREEN (1/2" - 3/4")	26.18
	LS780	80 MESH SCREEN (1/2" - 3/4")	28.80
5	LS120	20 MESH SCREEN (1" - 1 1/4")	28.80
	LS140	40 MESH SCREEN (1" - 1 1/4")	28.80
	LS180	80 MESH SCREEN (1" - 1 1/4")	26.18
5	LS206	6 MESH SCREEN (1 1/2" - 2")	56.98
	LS212	12 MESH SCREEN (S 1 1/2" - 2")	51.80
	LS220	20 MESH SCREEN (1 1/2" - 2")	
	LS230	30 MESH SCREEN (1 1/2" - 2")	
	LS250	50 MESH SCREEN (1 1/2" - 2")	
	LS280	80 MESH SCREEN (1 1/2" - 2")	
	6	LS150-B	Y BODY, 1 1/2"
	LS200-B	Y BODY, 2"	

POLYPROPYLENE "T" LINE STRAINERS LST-075, LST-100, LST-125, LST-150

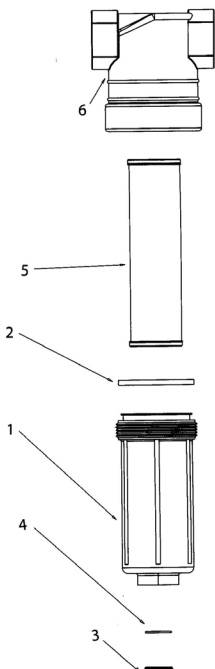

ITEM	PART NO.	DESCRIPTION	PRICE
5	LST116	16 MESH SCREEN - GRAY -(3/4" AND 1")	25.12
	LST130	30 MESH SCREEN - YELLOW -(3/4" AND 1")	
	LST150	50 MESH SCREEN - RED -(3/4" AND 1")	22.84
	LST180	80 MESH SCREEN - BLUE -(3/4" AND 1")	
	LST1100	100 MESH SCREEN - GREEN -(3/4" AND 1")	24.53
	LST1516	16 MESH SCREEN - GRAY -(1 1/4" AND 1 1/2")	38.59
	LST1530	30 MESH SCREEN - YELLOW -(1 1/4" AND 1 1/2")	
	LST1550	50 MESH SCREEN - RED -(1 1/4" AND 1 1/2")	
	LST1580	80 MESH SCREEN - BLUE -(1 1/4" AND 1 1/2")	
	LST15100	100 MESH SCREEN - GREEN -(1 1/4" AND 1 1/2")	
1	LST100-B	BOWL, POLY (3/4" AND 1")	16.93
	LST150-B	BOWL, POLY (1 1/4" AND 1 1/2")	28.25
2	LST100-G	GASKET (3/4" AND 1")	4.46
	LST100-GV	GASKET (3/4" AND 1" VITON)	9.25
	LST150-G	GASKET (1 1/4" AND 1 1/2")	4.46
	LST150-GV	GASKET (1 1/4" AND 1 1/2" VITON)	10.32
3	12777	CLEAN-OUT PLUG 1/2"	3.28
	LSQ200-PL	CLEAN OUT PLUG	3.81
4	UV15163	O'RING FOR CLEAN OUT PLUG - EPDM	1.20
	UV15163V	O'RING FOR CLEAN OUT PLUG - VITON	4.90
	LSQ200-R	O'RING FOR CLEAN OUT PLUG	1.20
	LSQ200-RV	O'RING FOR CLEAN OUT PLUG - VITON	1.92
6	LST075-H	3/4" HEAD, POLY	14.75
	LST100-H	1" HEAD, POLY	
	LST125-H	1 1/4" HEAD, POLY	32.24
	LST150-H	1 1/2" HEAD, POLY	

DIAPHRAGM CHECK VALVES

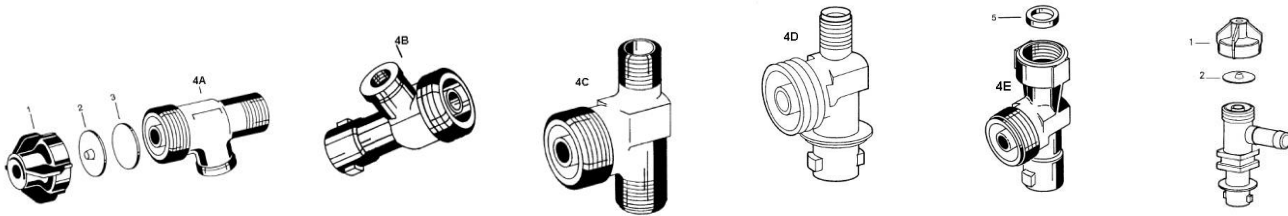

ITEM	PART NO.	DESCRIPTION	PRICE
1	21950-10-NYB	END CAP ASSEMBLY, CELCON (STANDARD)	4.35
	21950-2-NYB	END CAP ASSEMBLY, 2 LBS	
	21950-8-NYB	END CAP ASSEMBLY, 8 LBS	
	21950-20-NYB	END CAP ASSEMBLY, 20 LBS	
2	CP21953-EPR	DIAPHRAGM, EPDM RUBBER (STANDARD)	0.57
	CP21953-VI	DIAPHRAGM, VITON (OPTIONAL)	1.78
3	CP6227-TEF*	DIAPHRAGM, TEFLON (OPTIONAL)	0.93
4A	CP8296-1/8-NYB	BODY FOR 8355-1/8-NYB	19.77
	CP8296-1/4-NYB	BODY FOR 8355-1/4-NYB	21.46
4B	CP18676-1/8-NYB	QUICK JET BODY FOR QJ8355-1/8-NYB	8.98
	CP18676-1/4-NYB	QUICK JET BODY FOR QJ8355-1/4-NYB	
4C	CP8295-1-NYB	BODY FOR 8360-NYB	12.68
4D	CP18671-NYB	QUICK JET BODY FOR QJ8360-NYB	4.97
4E	CP19012-1-NYB	QUICK JET BODY FOR QJT8360-NYB	5.61
5	CP20266-EPDM	GASKET FOR QJT-8360-NYB, EPDM RUBBER	2.22

*WHEN THE CP6227-TEF TEFLON DIAPHRAGM IS USED, IT IS PLACED IN THE ASSEMBLY IN FRONT OF THE CP21953-EPR RUBBER DIAPHRAGM.

QJ360C MULTIPLE NOZZLE

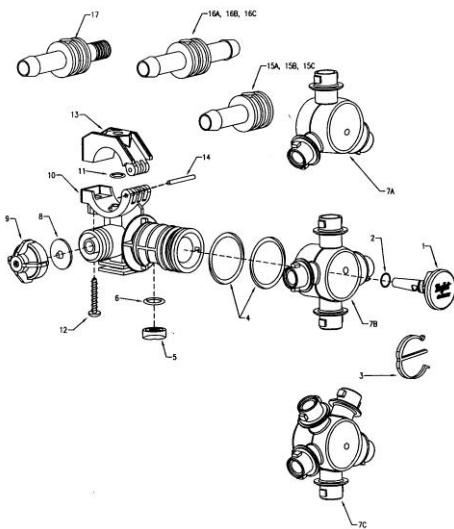

ITEM	PART NO.	DESCRIPTION	PRICE
1	CP38930-8-NYB	PLUG, NYLON	1.79
2	CP7717-2/13-EPR	O'RING, EPDM	2.74
	CP7717-2/13-VI	O'RING, VITON (OPTIONAL)	7.20
3	CP38931-NYB	E-CLIP, NYLON	1.79
4	CP7717-M28X3-EPRTE	O'RING, EPR-TEFLON FILLED (2 REQD)	3.88
	CP7717-M28X3-VITFE	O'RING, VITON-TEFLON FILLED (2 REQD)	10.61
5	CP56726-VITFE	SEAL, VITON-TEFLON FILLED	6.51
6	CP7717-2/111-VI	O'RING, VITON	7.20
7A	CP38921-2-NYB	TURRET, NYLON (3 OUTLET)	5.40
7B	CP38922-2-NYB	TURRET, NYLON (4 OUTLET)	5.80
7C	CP38923-2-NYB	TURRET, NYLON (5 OUTLET)	6.16
8	CP21953-EPR	DIAPHRAGM, EPDM	0.71
	CP21953-VI	DIAPHRAGM, VITON (OPTIONAL)	1.78
9	21950-10-NYB	END CAP SUB-ASSEMBLY, NYLON	4.35
10	CP38925-2-NYB	3/4" BODY, NYLON	5.94
11	CP7717-2/110-BU	O'RING, BUNA-N	0.76
	CP7717-2/110-VI	O'RING, VITON(OPTIONAL)	1.14
12	CP48255-1-1/4-302SS	SCREW, STAINLESS STEEL	3.96
13	CP48221-NYB	3/4" UPPER CLAMP, NYLON	2.09
14	CP48256-SS	PIVOT PIN, STAINLESS STEEL	1.10
15A	CP38936-NYB	1/2" SINGLE HOSE BARB, NYLON	2.85
15B	CP38938-NYB	3/4" SINGLE HOSE BARB, NYLON	
15C	CP38940-NYB	1" SINGLE HOSE BARB, NYLON	
16A	CP38937-NYB	1/2" DOUBLE HOSE BARB, NYLON	3.38
16B	CP38939-NYB	3/4" DOUBLE HOSE BARB, NYLON	
16C	CP38941-NYB	1" DOUBLE HOSE BARB, NYLON	
17	CP38948-NYB	3/4" HOSE BARB X 1/2" NPT, NYLON	

WILGER FLOW MONITOR

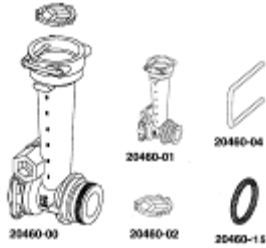
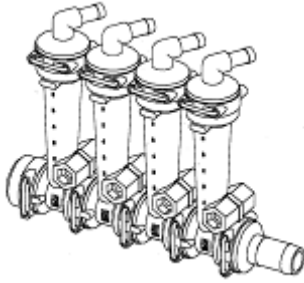

PART NO.	DESCRIPTION	PRICE
20460-00-VO	FLOW INDICATOR ASSEMBLY	26.23
20460-01	FLOW INDICATOR BODY	15.61
20460-02	BALL RETAINER	0.70
20460-15	O'RING, VITON (BODY AND FITTINGS)	2.12
20460-04	LOCK U-CLIP, 302SS	1.69
20501-VO	ORS X HOSE SHANK W/VITON O'RING - 3/8"	5.00
20502-VO	ORS X HOSE SHANK W/VITON O'RING - 1/2"	
20503-VO	ORS X HOSE SHANK W/VITON O'RING - 3/4"	
20511-VO	ORS X HOSE SHANK - EL W/VITON O'RING - 3/8"	5.00
20512-VO	ORS X HOSE SHANK - EL W/VITON O'RING - 1/2"	
20513-VO	ORS X HOSE SHANK - EL W/VITON O'RING - 3/4"	
20519-VO	ORS MALE X 1/4" NPT W/VITON O'RING	5.00
20520-VO	ORS MALE - ORS FEMALE EL END CAP W/CLIP & VITON O'RING	8.60
20521-00	ORS CAP W/CLIP (NO O'RING REQUIRED)	3.77
20526-VO	ORS MALE X MALE X ORS FEMALE TEE W/CLIP & VITON O'RING	12.16
20523-VO	ORS MALE X ORS FEMALE X 3/8" NPT - ISOLATOR TEE W/CLIP & VITON O'RING	8.96
20525-VO	ORS MALE X MALE X 1" NPT TEE W/VITON O'RING	12.16
21055-VO	ORIFICE INSERT ASSY W/VITON O'RING	6.07
20460-08	FLOW INDICATOR BALL - GREEN	0.82
20460-07	FLOW INDICATOR BALL - RED	0.82
20460-06	FLOW INDICATOR BALL - RED GLASS	0.82
20460-05	FLOW INDICATOR BALL 1/2" SS	1.71
20460-10	FLOW INDICATOR BALL - 7/16" SS	1.84

ISOLATED AND LOW FLOW MONITOR

20470-VO	LOW FLOW MONITOR ASSY	26.23
20480-00-VI	ISOLATED FEED ASSY(BOTTOM)	25.72
40424-05	RADIAKOCK CAP - 3/8" HOSE BARB	1.28
40260-VO	NOZZLE SEAL - VITON	1.98
40261-00	SEAL/STRAINER ADAPTER	0.38
40273-05	RADIALOCK CAP 1/4"NPTF	1.29

JOHN BLUE MONITOR

PARTS LIST

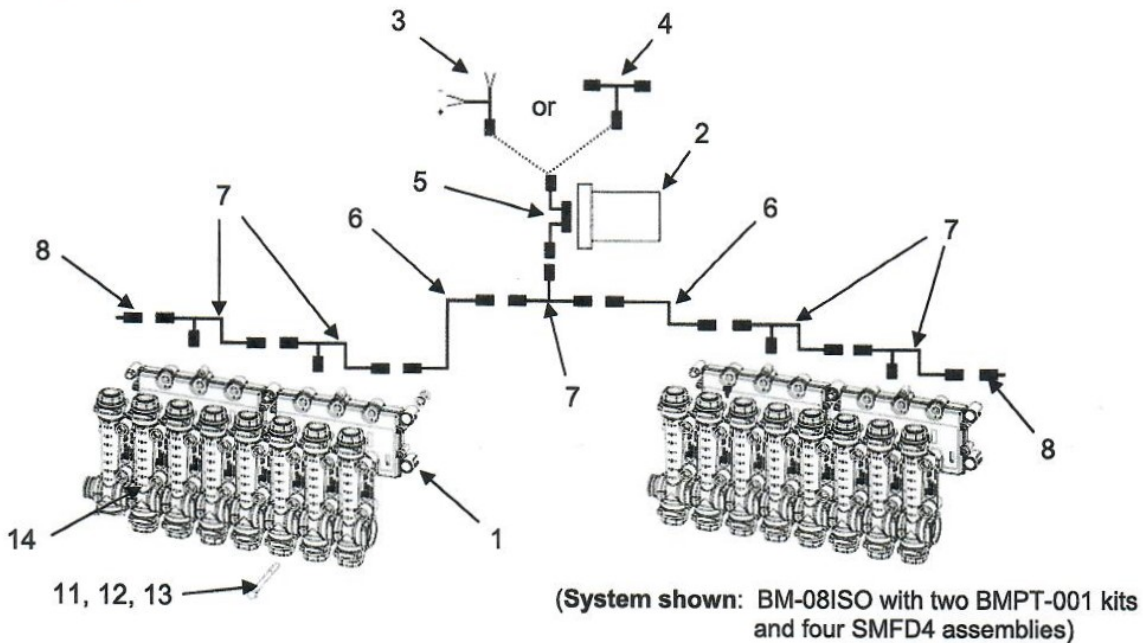

ITEM #	PART #	DESCRIPTION	QTY	PRICE
1	BMPT-002	STANDARD SENSOR	VARIABLE	439.65
2	BMPT-030	JOB COMPUTER	1	362.35
3	BMPT-034	UNIVERSAL INPUT HARNESS	1	36.80
4	BMPT-032	DEERE CANBUS TAP HARNESS	2	92.82
5	BMPT-031	COMPUTER HARNESS	1	133.13
6	BMPT-012	15 FT EXTENSION HARNESS	1	100.20
7	BMPT-011	TEE HARNESS	VARIABLE	72.93
8	BMPT-015	TERMINATOR PLUG	2	14.39
9	BMPT-012	28 FT EXTENSION HARNESS NOT SHOWN	OPTIONAL	100.20
10	BMPT-014	7 FT EXTENSION HARNESS NOT SHOWN	OPTIONAL	54.30
11	90623	1/4" - 20 X 3" LONG SS HEX BOLT	8 PER SENSOR	
12	93005	1/4" PLATED LOCK WASHER	8 PER SENSOR	0.04
13	92015	1/4" -20 PLATED NUT	8 PER SENSOR	0.06
14	SMFD4	VISAGAGE SET - SOLD SEPARATELY		88.25
15	SMPT-0057	ORANGE LOW FLOW MAGNET BALL	4 PER SET (#21)	4.54
16	SMPT-0058	YELLOW STANDARD MAGNET BALL	4 PER SET (#21)	4.54
17	SMPT-0068	GREEN MEDIUM FLOW MAGNET BALL	4 PER SET (#21)	6.27
18	SMPT-0079	OPTIONAL BLUE HIGH FLOW MAGNET BALL	OPTIONAL	6.27
19	SMPT-0085	OPTIONAL GREY MAGNET BALL	OPTIONAL	4.54

KITS: BMPT-001 SENSOR EXPANSION KIT (INCLUDES ITEMS: 1,7,21, AND EIGHT EACH OF 11,12,13 \$503.15
 #21 - SMPT-0060 12 MAGNET BALL KIT FOR ONE SENSOR (FOUR EACH OF 15,16,17) \$53.85

BMPT-0036 UNIVERSAL ISOBUS CONVERSION KIT FOR BMI-08 (TABLE VERSION) \$1941.21
 BMPT-036-JD DEERE ISOBUS CONVERSION KIT FOR BMI-08 (TABLET VERSION) \$1987.77
 BMPT-037 UNIVERSAL ISOBUS CONVERSION KIT FOR BM-08PL & AP (STD VERSION) \$1478.61
 BMPT-036-JD DEERE ISOBUS CONVERSION KIT FOR BM-08PL & AP (STD VERSION) \$1525.19

JOHN BLUE SINGLE MONITOR

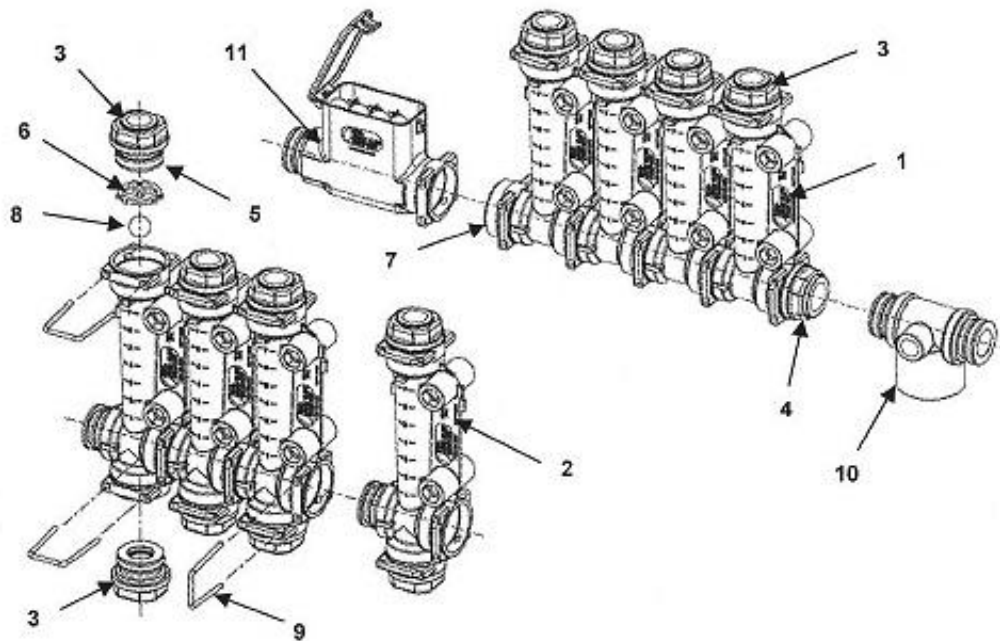

ITEM #	PART #	DESCRIPTION	PRICE
1	SMPT-0001	SPRAY TYPE COLUMN – PVC	4.10
1F	SMPT-0043F	FUMIGANT SPRAY TYPE COLUMN – PSU	18.88
2	SMPT-0002	FLOW DIVIDER TYPE COLUMN – PVC	4.45
2F	SMPT-0044F	FUMIGANT FLOW DIVIDER TYPE COLUMN – PSU	19.25
3	SMPT-0003	3/8" FEM NPT ADAPTER – POLY	1.50
4	SMPT-0004	1/2" FEM NPT ADAPTER – INLET – POLY	1.51
5	SMPT-0007	#212 VITON ORING	2.34
6	SMPT-0005	UPPER BALL SCREEN – POLY	1.22
7	SMPT-0008	END CAP – POLY	1.04
8	SMPT-0016	GREEN PLASTIC BALL – POLY	1.26
	SMPT-0017	BLACK PLASTIC BALL - PLOY	1.17
	SMPT-0018	BLUE PLASTIC BALL – DELRIN	1.22
	SMPT-0019	BLUE GLASS BALL	2.22
	SMPT-0020	316 SS BALL – 1/2"	2.51
	SMPT-0013	SET OF REPLACEMENT BALLS (0016-0020, 4 EA)	7.82
9	SMPT-0006	RETAINER CLIP	1.26
10	SMPT-0014	MANIFOLD TEE & ORING – OPTIONAL	8.15
11	SMPT-0009	BALL STORAGE UNIT – OPTIONAL	9.10
	SMPT-0034	#112 VITON ORING (ORIFICE PLATE)	1.01
	SMSS1	SINGLE COLUMN ASSY – SPRAY TYPE	25.90
	SMSS4	FOUR COLUMN ASSY- SPRAY TYPE	82.91
	SMFD1	SINGLE COLUMN ASSY – FLOW DIVIDER	23.28
	SMFD4	FOUR COLUMN ASSY – FLOW DIVIDER	88.25
		(-FUM = OPTIONAL FUMIGANT VERSION)	

SERIES 1700 HYPRO ROLLER PUMP

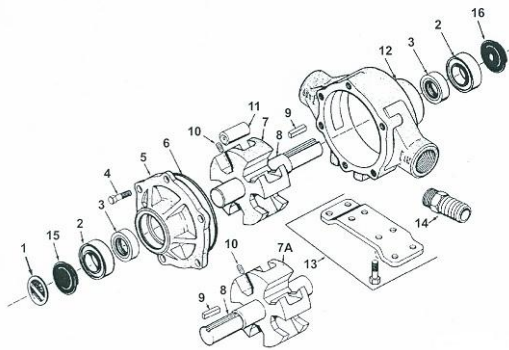

ITEM	PART NO.	DESCRIPTION	REQD	PRICE
1		N/A		
2	2008-0001	SEALED BALL BEARING	2	16.72
3	2112-0003	VITON SEAL	2	18.43
4	2210-0005	BOLT	6	0.84
5	0200-1700C	ENDPLATE	1	146.64
	0200-1700N	ENDPLATE	1	408.72
	0200-1700X	ENDPLATE	1	633.36
6	1720-0099	O'RING	1	2.25
7	0300-1700C	ROTOR W/SHAFT	1	212.16
	0300-1700N	ROTOR W/SHAFT	1	501.28
	0300-1700X	ROTOR W/SHAFT	1	625.04
8	0500-1502	SHAFT ONLY	1	70.20
9	1610-0005	KEY	1	1.80
10	2230-0018	SET SCREW	1	0.85
11	1005-0005	SUPER ROLLER	5	8.95
12	0100-1700C	BODY	1	283.92
	0100-1700N	BODY	1	955.76
	0100-1700X	BODY	1	1260.48
13		N/A		
14		N/A		
15	2300-0020	BEARING COVER	1	1.63
16	2300-0022	SHAFT BEARING COVER	1	1.63

3430-0437 REPAIR KIT: \$80.86
 CONSIST OF: FIVE NO. 1005-0005 SUPER ROLLERS
 ONE NO. 1720-0099 O'RING
 TWO NO. 2112-0003 VITON SEALS

3430-0383 REPAIR KIT (UNIVERSAL) \$92.56
 CONSIST OF: SIX 1005-0005 SUPER ROLLERS
 TWO NO. 1720-0099 O'RING
 TWO NO. 2112-0003 VITON SEALS

SERIES 6500 HYPRO ROLLER PUMP

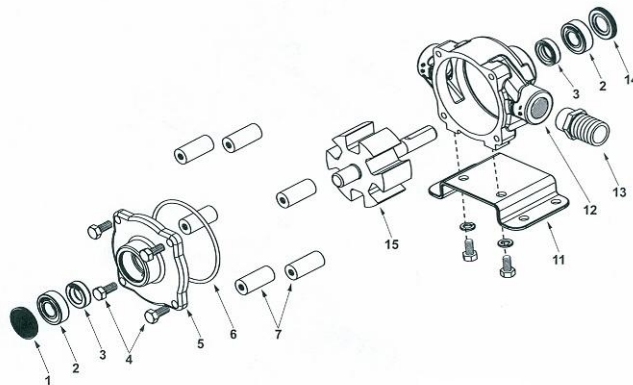

ITEM	PART NO.	DESCRIPTION	REQD	PRICE
1	2300-0021	BEARING COVER	1	1.63
2	2000-0010	SEALED BALL BEARING	2	11.28
3	2107-0002	VITON SEAL	2	11.63
4	2210-0004	BOLTS	4	1.01
5	0200-6600C	ENDPLATE	1	66.30
	0200-6600N	ENDPLATE	1	188.24
	0200-6600X	ENDPLATE	1	258.96
6	1720-0008	O'RING	1	1.68
7	1005-0004	SUPER ROLLER	6	4.08
11	3420-0023	BASE KIT	1	39.78
12	0100-6600C	BODY	1	117.52
	0100-6600N	BODY	1	3372.32
	0100-6600X	BODY	1	513.76
14	2300-0023	SHAFT BEARING COVER	1	1.71
15	0300-6600C	ROTOR ASSY -CI	1	130.00

3430-0380 REPAIR KIT: \$47.84
 CONSIST OF: SIX NO. 1005-0004 ROLLERS
 ONE NO. 1720-0008 O'RING
 TWO NO. 2107-0002 VITON SEAL

SERIES 7560 - 7700 HYPRO ROLLER PUMPS

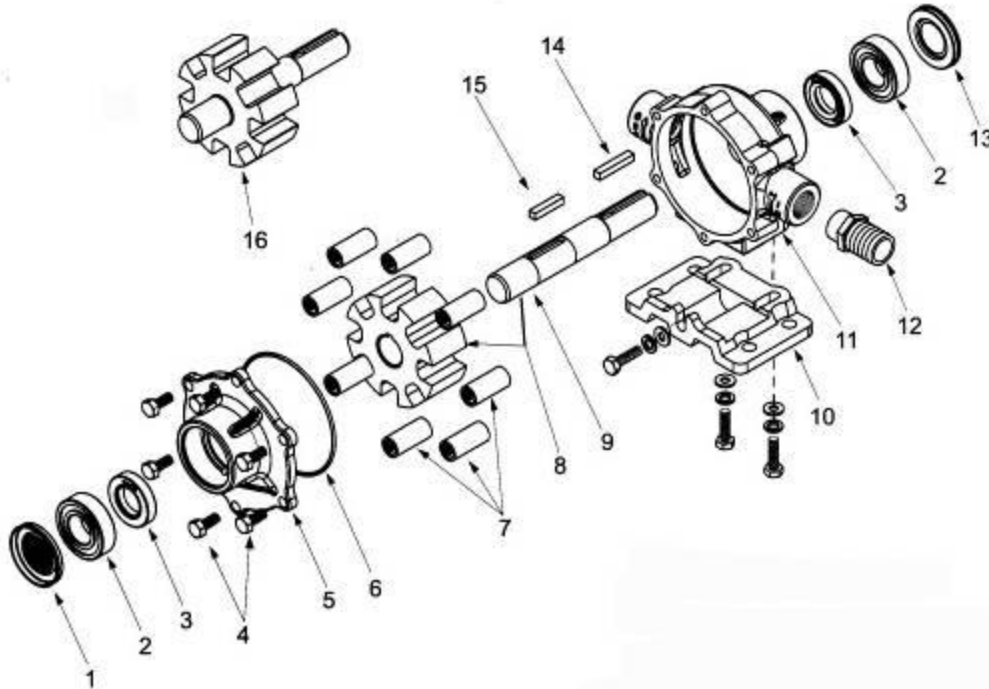

ITEM	PART NO.	DESCRIPTION	REQD	PRICE
1	2300-0020	BEARING COVER	1	1.63
2	2008-0001	SEALED BALL BEARING	2	16.72
*3	2112-0003	VITON SEAL	2	18.43
4	2210-0004	BOLTS	6	1.01
5	0204-7500C	ENDPLATE	1	87.36
	0204-7500N	ENDPLATE	1	231.92
	0204-7500X	ENDPLATE	1	318.24
	0200-7700C	ENDPLATE	1	87.88
	0200-7700N	ENDPLATE	1	241.28
	0200-7700X	ENDPLATE	1	453.44
*6	1720-0014	O'RING	1	2.48
*7	1005-0004	SUPDR ROLLER	7	4.08
8	3430-0745	ROTOR ASSY (STD N & XL)	1	241.28
9	0510-7500	SHAFT (7560 ONLY)	1	49.92
10	3420-0010	BASE KIT	1	62.92
	3420-0003	BASE KIT - 7560	1	62.40
11	0104-7500C	BODY	1	144.56
	0104-7500N	BODY	1	453.44
	0104-7500X	BODY	1	638.56
	0100-7700C	BODY	1	160.16
	0100-7700N	BODY	1	491.92
	0100-7700X	BODY	1	707.20
13	2300-0022	SHAFT BEARING COVER	1	1.63
14	1610-0005	KEY	1	1.80
15	1610-0059	KEY(7560 ONLY)	1	4.99
16	0308-7560C	ROTOR ASSY (CI 7560 ONLY)	1	150.80
	0300-7700C	ROTOR ASSY (CI)	1	191.36
	0300-7700N	ROTOR ASSY (NR)	1	425.36
	0300-7700X	ROTOR ASSY (SC)	1	438.88
	0301-7700C	ROTOR ASSY (CI REV ROV)	1	184.08
*3430-0381	REPAIR KIT:	EIGHT NO. 1005-0004 ROLLER		\$68.38
		ONE NO. 1720-0014 O'RING		
		TWO NO. 2112-0003 SEALS		

HYPRO MODELS 9006C-O, 9016C-O, 9008C-O, AND 9028C-O

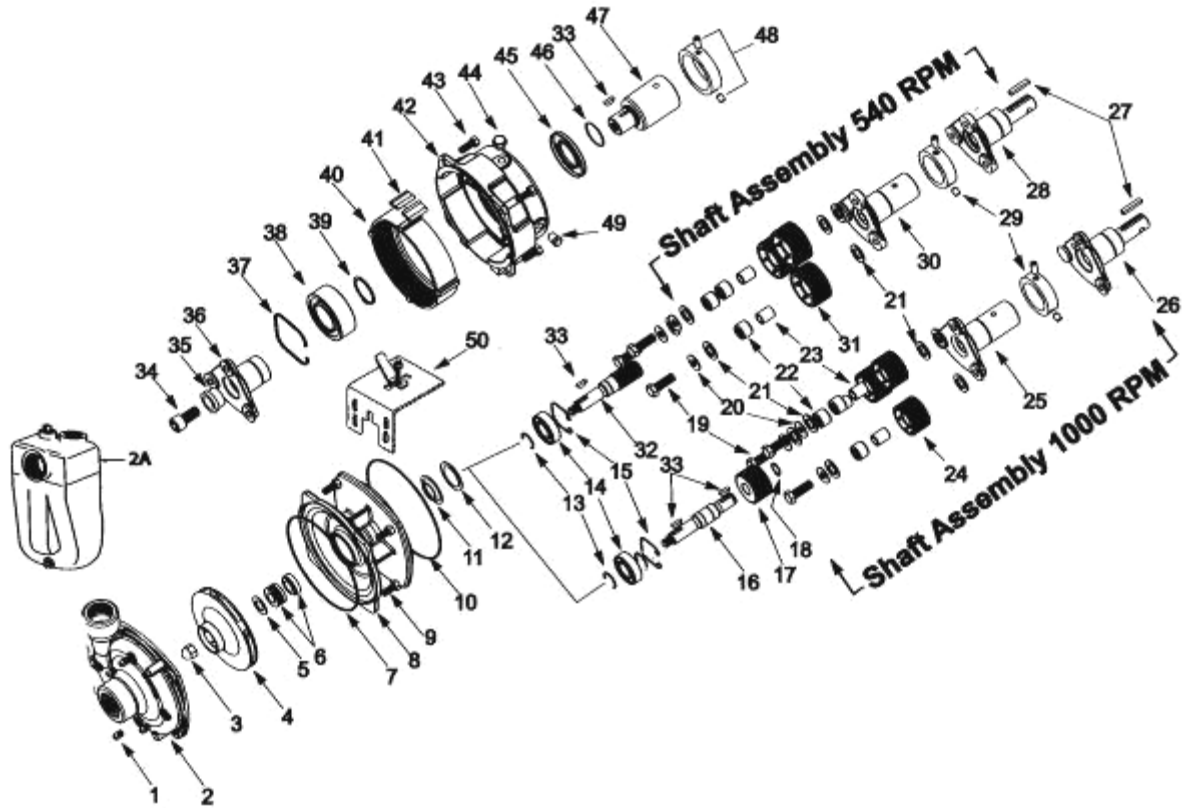

ITEM	PART NO.	DESCRIPTION	REQ'D	PRICE
1	2406-0007	DRAIN PLUG	4	1.10
2	0150-9000C	PUMP CASING(W/SS WEAR RING)	1	250.64
2A	3430-0480SP	PUMP CASING(SELF-PRIMING)	1	382.72
3	2253-0001	IMPELLER NUT	1	6.99
4	0400-9000P	IMPELLER(NYLON)	1	60.32
5	1700-0101	GASKET	1	6.13
6	2120-0010	MECHANICAL SEAL(OPTIONAL BUNA-N)	1	34.84
7	1720-0083	O'RING	1	3.72
8	0752-9000C	MOUNTING FLANGE ADAPTER	1	295.36
9	2210-0020	HEX HEAD CAPSCREW	4	1.01
10	1720-0139	O'RING	1	3.61
11	2130-0018	BEARING LIP SEAL	1	27.47
12	1700-0098	GASKET	1	1.09
13	1810-0013	RETAINING RING - 1 FOR 540 RPM 2 FOR 1 3/8" AND 3 FOR 1000 RPM	-	1.05
14	2008-0001	BALL BEARING	1	16.72
15	1820-0025	RETAINING RING	1	4.23
16	0500-9002	IMPELLER SHAFT (1000 RPM)	1	250.64
17	3900-0013	SUN GEAR (1000 RPM)	1	206.96
18	1810-0011	RETAINING RING (1000 RPM)	1	1.37
19	2210-0046	HEX HEAD CAPSCREW	3	4.30
20	2270-0003	WASHER	3	1.09
21	2265-0003	THRUST WASHER	6	1.51
22	2007-0052	BEARING(INCLUDED WITH DRIVER GEAR)	3	14.03
23	2007-0022	BEARING INNER RACE	3	6.80
24	3900-0040	DRIVER GEAR W/BEARING(1000 RPM)	3	62.40
25	0562-9002D	DRIVER HUB(MODEL 9008C-O)	1	310.96
26	0501-9018D	DRIVER HUB(MODEL 9018C)	1	288.08
27	1610-0005	KEY	1	1.80
28	0501-9016D	DRIVER HUB(MODEL 9016C-O)	1	229.84
29	3435-0058	LOCKING COLLAR KIT-(HOLLOW SHAFT)	1	53.82
30	0562-9000D	DRIVER HUB(MODEL 9006C-O)	1	218.40
31	3900-0039	DRIVER GEAR W/BEARING(540 RPM)	3	41.86
32	3900-0010	IMPELLER SHAFT/PINION GEAR(540 RPM)	1	218.40
33	1610-0012	WOODRUFF KEY - 1 FOR 540 RPM, 2 FOR 1000 RPM	-	1.37
34	2220-0035	CAPSCREW(MODEL 9028C)	1	11.28

ITEM	PART NO	DESCRIPTION	REQ'D	PRICE
35	2403-0012	BUSHING(MODEL 9028C)	1	49.14
36	0501-9018D1	DRIVER HUB(MODEL 9028C)	1	302.64
37	1800-0014	RETAINING RING	1	23.74
38	2005-0006	BALL BEARING	1	141.44
39	1810-0001	RETAINING RING	1	1.81
40	3900-0009	RING GEAR	1	86.84
41	1450-0004	CUSHION BUMPER	8	1.14
42	0754-9000C	GEAR CASING	1	203.84
43	2210-0026	HEX HEAD CAPSCREW	4	1.11
44	2404-0193	BREATHER VENT	1	23.74
45	2102-0025	OIL SEAL	1	16.89
46	1720-0022	O'RING	1	1.05
47	0550-1322F4	DRIVER HUB(9028C) 0550-1322F 3/4" GREASE BOTH KEYWAY SHAFT	1	385.84
48	3430-0190	LOCKING COLLAR KIT(MODEL 9028C)	1	71.50
49	2406-0019	OIL PLUG	4	1.83
50	1520-0034	MOUNTING CLIP	1	86.32

SEAL, O'RING REPAIR KIT 3430-0334 \$56.16
 ONE - 1700-0101 GASKET
 ONE - 2120-0011 MECHANICAL SEAL
 ONE - 1720-0083 GASKET

LIFEGUARD SEAL KIT 3430-0591 \$252.72
 ONE - 2120-0011 - SILICON CARBIDE SEAL
 ONE - 1720-0083 - O'RING

GEAR LUBE REQUIREMENT: PHILLUBE SAE 80W90 OIL

9910-D30, AND 9910-D30GRGI DIAPHRAGM PUMP

ITEM	PART NO.	DESCRIPTION	REQ'D	PRICE
1	9910-629011	PUMP BODY W/BOLTS	1	313.56
2	9910-620101	RIGHT HEAD ASSEMBLY (DX)	1	148.74
3	9910-620102	LEFT HEAD ASSEMBLY (SX)	1	153.77
4	9910-621430	BOLT 12 X 55	8	3.73
#5	9910-620085	DIAPHRAGM (DESMOPAN)(STD.)	2	42.21
6	9910-620120	PISTON	2	68.59
7	9910-620140	CONNECTING ROD	2	57.54
8	9910-620110	SLEEVE	2	99.50
9	9910-580470	RETAINER RING	2	6.88
10	9910-380300	CONNECTING ROD PIN	2	31.16
11	9910-380080	RETAINER RING	4	2.12
12	9910-160230	PISTON RING	2	16.05
14	9910-1040180	RETAINING WASHER	2	20.70
15	9910-580360	DIAPHRAGM BOLT	2	16.30
16	9910-180150	NUT	2	2.02
*#@18	9910-620030	O'RING	4	2.17
@19	9910-1409050	CHECK VALVE ASSEMBLY	4	35.43
20	9910-111120	RETAINER RING	2	8.07
21	9910-620020	COVER	1	8.80
*22	9910-620210	O'RING	1	3.06
23	9910-620291	RETAINING RING	1	8.80
25	9910-850850	M6 X 30 BOLT	2	3.06
26	9910-550331	WASHER	2	1.86
*28	9910-180101	O'RING	2	1.97
29	9910-550030	OIL SIGHT GLASS	1	19.67
*30	9910-550040	O'RING	1	2.17
31	9910-550056	OIL SIGHT GLASS CAP	1	12.42
32	9910-620160	SPACER	1	5.90
33	9910-550060	ROLLER BEARING	1	76.38
34	9910-620130	SEAL	1	26.91
35	9910-620330	RETAINER RING	1	15.01
36	9910-620170	"SP" SHAFT	1	319.59
37	9910-620150	SUCTION MANIFOLD	1	116.58
38	9910-550340	THREADED ADAPTER	1	9.63
*39	9910-550350	O'RING	2	1.97
41	9910-550370	HOSE BARB 1"	1	16.30
*42	9910-390060	O'RING	4	1.97
44	9910-621780	M8 X 40 BOLT	8	3.52
45	9910-629211	UPPER AIR CHAMBER	1	107.54
#46	9910-550190	ACCUMULATOR DIAPHRAGM, BUNA-N	1	28.72

47	9910-622070	COMPLETE LOWR AIR CHAMBER	1	247.23
*49	9910-650542	O'RING	1	2.17
50	9910-180020	AIR VALVE	1	45.23
*51	9910-390290	O'RING	1	2.59
52	9910-620680	KEY (AP-A MODEL)	1	4.04
53	9910-620174	THRU-SHAFT 3/4" DIA. "AP VERSION"	11	480.39
58	9910-620630	SEAL	1	15.79
59	9910-620021	COVER	1	69.60
60	9910-650660	DIAPHRAGM HOLDER	1	46.98
61	9910-650670	SUCTION DIAPHRAGM	1	16.82
62	9910-650690	CLAMP	1	23.03
63	9910-1500350	PTO SHIELD	1	64.82
64	9910-820670	M10 X 16 BOLT	4	3.06
65	9910-620190	BEARING	1	201.00
66	2406-0023	DRAIN PLUG, OIL	1	10.16
*67	9910-740290	O'RING	1	2.12
68	9910-620930	SPACER	1	3.42
69	9910-620940	SPACER	1	3.42
70	9910-380230	BEARING	1	58.04
74	9910-390270	NUT	2	1.86
75	9910-450145	FLANGE	1	44.22
76	9910-110130	1/2" FITTING PLUS HOSE BARB	1	18.63

***O'RING PARTS KIT NO. 9910-KIT1916 \$60.05**

FOUR - 9910-620030 O'RINGS
 ONE - 9910-620210 O'RING
 TWO - 9910-180101 O'RINGS
 ONE - 9910-550040 O'RING
 TWO - 9910-550350 O'RINGS

ONE - 9910-740290 O'RING ONE -
 9910-390290 O'RING ONE -
 9910-650542 O'RING FOUR -
 9910-390060 O'RINGS

#DIAPHRAGM PARTS KIT NO. 9910-KIT1724 \$111.56

TWO - 9910-620085 DIAPHRAGM (DESMOPAN)
 ONE - 9910-550190 ACCUMULATOR DIAPHRAGM

FOUR - 9910-620030 O'RINGS

@VALVE PARTS KIT NO. 9910-KIT1917 \$177.89

FOUR - 9910-620030 O'RINGS
 FOUR - 9910-1409050 CHECK VALVE ASSEMBLY

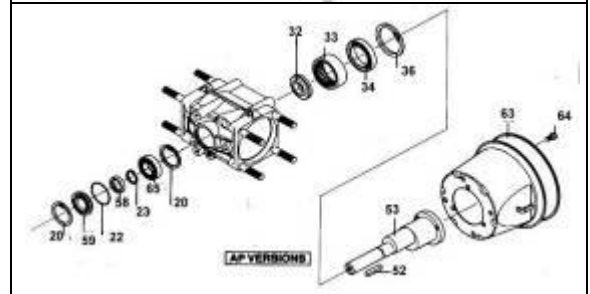
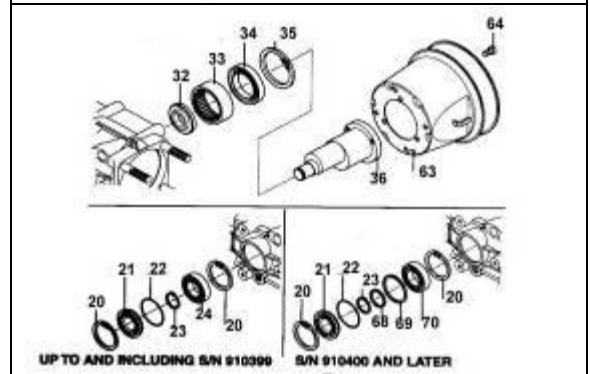
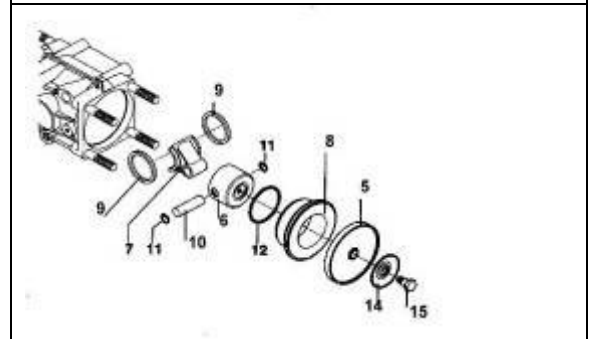
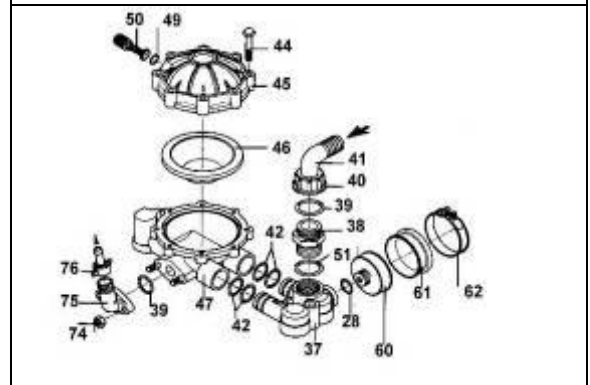
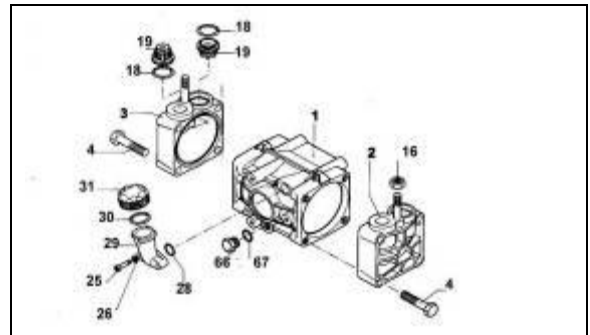

9910-GS40GI CONTROL KIT

USE WITH D30 & D50 PUMPS

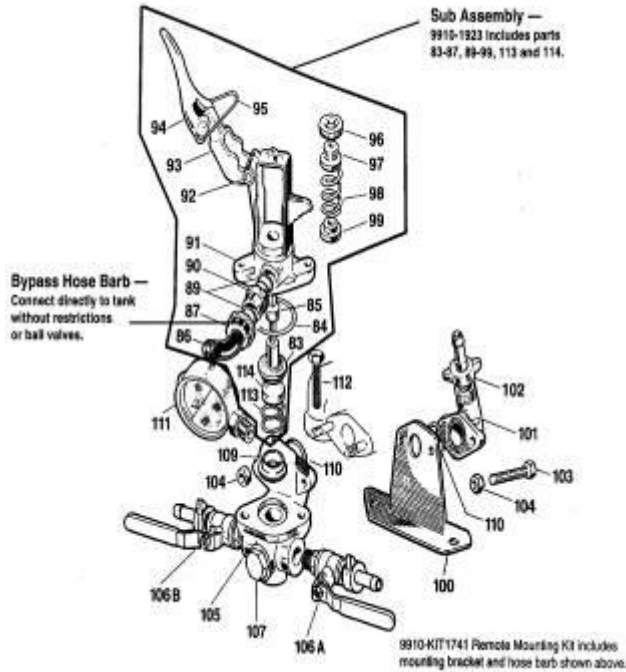

ITEM	PART NO.	DESCRIPTION	REQ'D	PRICE
*83	9910-320433	RELIEF VALVE POPPET RETAINER	1	20.19
*84	9910-320511	GASKET SEAL O'RING	1	4.96
*85	9910-390140	TENSION SPRING GUIDE/SEAL	1	10.87
86	9910-550460	HOSE BARB 1/2"	1	6.21
87	9910-550450	BARB NUT	1	4.86
89	9910-180101	O'RING	2	1.97
90	9910-550440	THREADED ADAPTER	1	5.39
91	9910-320410	TENSION SPRING HOUSING	1	68.09
92	9910-320480	PIN	1	3.52
93	9910-320460	LEVER GUIDE	1	34.42
94	9910-320470	PRESSURE RELEASE LEVER	1	25.10
95	9910-320490	LOCKING CLIP	1	8.59
96	9910-320450	PRESSURE ADJUSTMENT NUT	1	7.71
97	9910-320440	THREADED GUIDE	1	10.04
98	9910-110190	TENSION SPRING	1	6.73
99	9910-230120	TENSION SPRING RETAINER	1	6.47
100	9910-320406	REMOTE DISCHARGE MOUNTING BRACKET	1	43.47
101	9910-450145	DISCHARGE FLANGE HOUSING	1	44.22
102	9910-110130	1/2" HOSE BARB & NUT - 3/8"	1	18.63
103	9910-160660	BOLT (M8 X 35)	2	1.92
104	9910-390270	NUT	2	1.86
105	9910-620220	RELIEF VALVE BODY	1	93.21
107	9910-130171	PLUG	1	5.23
*109	9910-450110	SPRING HOLDER	1	17.60
110	9910-550350	O'RING	1	1.97
111	2640-0001	PRESSURE GAUGE(OIL FILLED)	1	44.98
112	9910-180370	BOLT(8MA X 25)	2	4.96
*113	9910-320420	TENSION SPRING	1	7.25
*114	9910-110122	RELEIF VALVE SEAT	1	36.93

***CONTROL UNIT KIT NO. 9910-KIT1757 \$106.53**
 ONE - 9910-320433 RELIEF VALVE POPPET RETAINER
 ONE - 9910-320511 GASKET SEAL O'RING
 ONE - 9910-390140 TENSION SPRING GUIDE/SEAL
 ONE - 9910-450110 SPRING HOLDER
 ONE - 9910-320420 TENSION SPRING
 ONE - 9910-110122 RELIEF VALVE SEAT

9910-KIT1640

USE WITH D30 PUMP

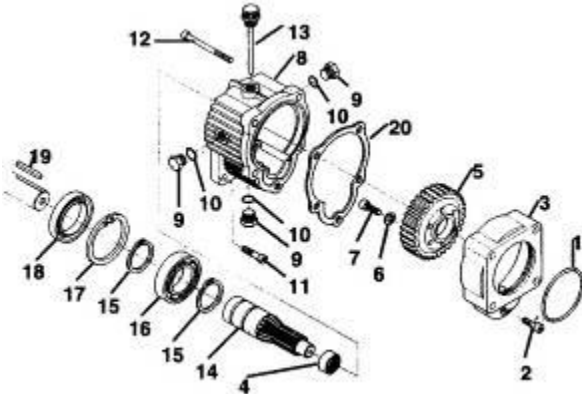

9910-KIT1642 GEARBOX

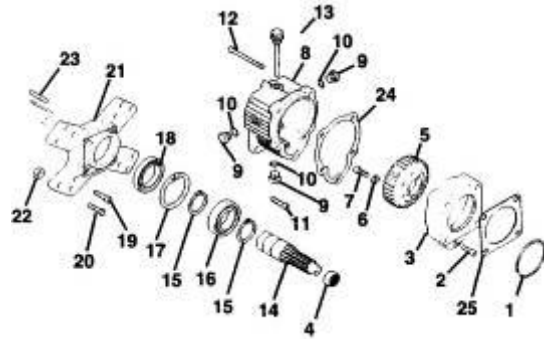

ITEM	PART NO.	DESCRIPTION	REQ'D	PRICE
1	9910-620561	O'RING	1	8.43
2	9910-180030	BOLT	1	2.12
3	9910-621000	PUMP ADAPTER FLANGE	1	230.15
4	9910-620990	BEARING	1	98.24
5	9910-651620	GEAR	1	291.45
6	9910-200231	LOCK WASHER	6	2.17
7	9910-620470	BOLT	3	3.06
8	9910-620960	GEARBOX BODY	1	243.21
9	2406-0023	PLUG	2	10.16
10	9910-740290	O'RING	2	2.12
11	9910-651000	BOLT	4	13.20
12	9910-621010	BOLT	4	6.67
13	9910-1140370	VENT PLUG	1	14.73
14	9910-621660	PINION GEAR	1	264.32
15	9910-320240	RETAINING RING(EXT)	2	3.78
16	9910-961780	BEARING	1	93.21
17	9910-961790	RETAINING RING	1	7.25
18	9910-961800	SEAL	1	33.17
19	9910-881090	KEY	1	12.42
20	9910-620950	GASKET	1	3.73

ITEM	PART NO.	DESCRIPTION	REQ'D	PRICE
1	9910-620561	O'RING	1	8.43
2	9910-180030	BOLT	1	2.12
3	9910-621000	PUMP ADAPTER FLANGE	1	230.15
4	9910-620990	BEARING	1	98.24
5	9910-651620	GEAR	1	291.45
6	9910-200231	LOCK WASHER	6	2.17
7	9910-160671	BOLT; 1" LONG (D50)	3	5.03
	9910-620470	BOLT; 3/4" SHORT (D30)	3	3.06
8	9910-620960	GEARBOX BODY	1	243.21
9	2406-0023	PLUG	3	10.16
10	9910-740290	O'RING	3	2.12
11	9910-540290	BOLT	4	3.68
12	9910-621010	BOLT	4	6.67
13	9910-1140370	VENT PLUG	1	14.73
15	9910-320240	RETAINING RING(EXT)	2	3.78
16	9910-961780	BEARING	1	93.21
17	9910-961790	SNAP RING	1	7.25
18	9910-961800	SEAL	1	33.17
19	9910-651000	BOLT	4	13.20
20	9910-961900	BOLT	4	4.60
21	9910-1320940	ENGINE ADAPTER FLANGE	1	129.65
22	9910-961770	WASHER	4	15.53
23	9910-650990	KEY	1	16.56
24	9910-620950	GASKET	1	3.73
25	9910-650270	GASKET	1	3.68

JOHN BLUE NGP 405x, 605x, AND 705x SERIES PUMPS

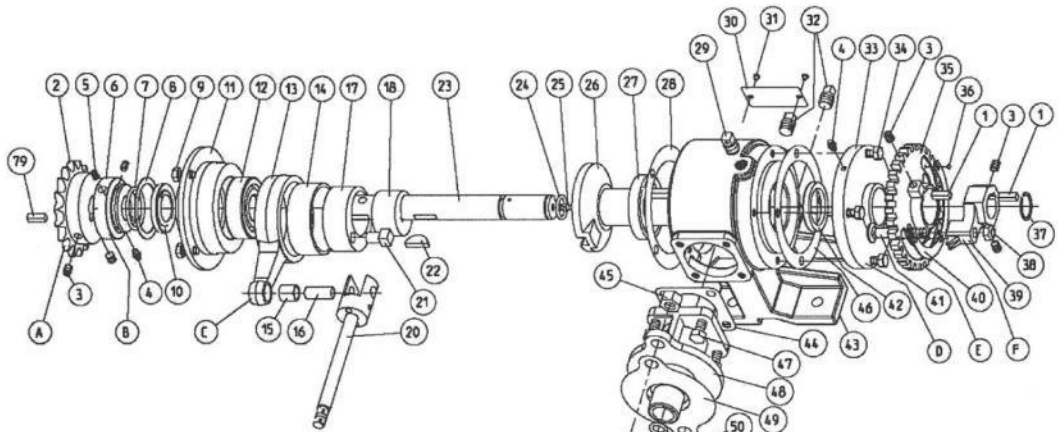

ITEM	DESCRIPTION	INCLUDES ITEM #'S
A	SPROCKET	2 3
B	SPACER	4 5 6 7 8
C	CONNECTING ROD	13 14 15
D	FLANGE COVER	4 33
E	SETTING HUB	3 35 36 40
F	SETTING POINTER	3 39
G	GASKET KIT	7 8 10 15 24 28 37 42 44 49 50 51 52 53 56 58 59 60 66 67 68
H	OPERATORS KIT	NOT SHOWN

- (G) — GASKET KIT
- (H) — OPERATORS KIT
 - MANUAL
 - WRENCH
 - SLIDE CHART
 - MOUNTING HARDWARE

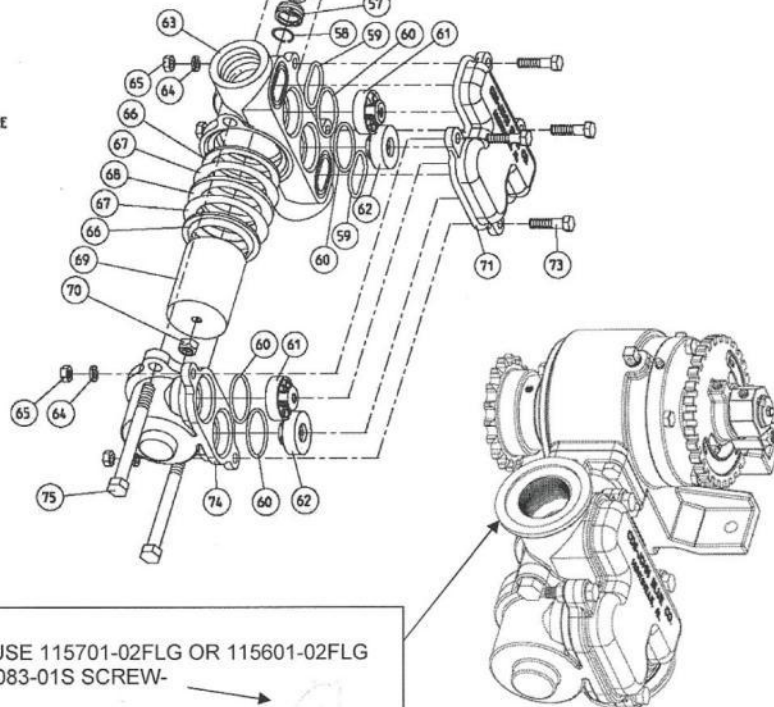

220 FLANGE ADAPTERS:
 - CAST IRON PUMPS USE 115701-02FLG OR 115601-02FLG
 - STAINLESS USE 116083-01S SCREW-IN ADAPTERS

PARTS LISTING – NGP- 405x / 605x / 705x Series

ITEM	PART DESCRIPTION	NGP-4050 PART #	NGP-6050 PART #	NGP-7050 PART #	ITEM	PART DESCRIPTION	NGP-4050 PART #	NGP-6050 PART #	NGP-7050 PART #
1	KEY	L-1020	L-1020	L-1020	55	STUFFING BOX	116070-01	115790-01	115690-01
2	SPROCKET RC50-18T	112661-01	112661-01	112661-01	-S	STAINLESS	N/A	115790-01S	115690-01S
-K	NO SPROCKET	NOT USED	NOT USED	NOT USED	56	INBOARD CYL. GASK.	116076-01	115710-01	115710-01
-R	SPROCKET RC40-18T	113905-01	113905-01	113905-01	-U	FUMIGANT	N/A	104826-02	104826-02
3	5/16x3/8 SETSCREW	90532	90532	90532	57	STUFF. BOX INSERT	116068-01	L-1031-2	L-1031-2
4	GREASE FITTING	H-28	H-28	H-28	-S	STAINLESS	NOT USED	NOT USED	NOT USED
5	5/16x3/8 SETSCREW	90532	90532	90532	58	PACKING - SNAP RING	112698-01	L-1042	L-1042
6	SPROCKET SPACER	115625-01	115625-01	115625-01	-S	STAINLESS AND FUM.	N/A	116210-01	116210-01
7	O-RING	S-316	S-316	S-316	59	O-RING	S-316	S-316	115604-01
8	THRUST WASHER	115626-01	115626-01	115626-01	-S	STAINLESS	N/A	104824-01	115612-01
9	5/16x1 HEX BOLT	90637	90637	90637	-U	FUMIGANT	N/A	104824-01	115612-01
10	OIL SEAL	115621-01	115621-01	115621-01	60	O-RING	S-316	L-3031	A-2848
11	COVER PLATE	115723-01	115723-01	115623-01	-S	STAINLESS	N/A	114768-01	114870-01
12	BEARING	L-3019	L-3019	L-3019	-U	FUMIGANT	N/A	114768-01	114870-01
13	CONNECTING ROD	L-1008-A	L-1008-A	113630-01	61	DISCHARGE VALVE	116127-91	115707-91	115607-91
14	JOURNAL BEARING	L-928	L-928	113629-01	62	SUCTION VALVE	116126-91	115706-91	115606-91
15	ROD BUSHING	113588-01	113588-01	113588-01	63	INBOARD CYLINDER	N/A	115701-02	115601-02
16	ROD PIN	105895-01	105895-01	105895-01	-F	FLANGED	116071-01	115701-02FLG	115601-02FLG
17	ECCENTRIC - OUTER	L-1013-A	L-1013-A	113633-01	-S	STAINLESS	N/A	115701-02S	115601-02S
18	ECCENTRIC - INNER	L-1015	L-1015	L-3017	64	3/8 LOCK WASHER	93024	93024	93024
19	NOT USED				-S	STAINLESS	N/A	93025	93025
20	PISTON ROD ASM	116078-91	115712-91	105900-91	65	3/8 HEX NUT	92024	92024	92024
21	ECCENTRIC PIN	L-3004	L-3004	L-3004	66	PLUNGER – PACKING	112696-01	L-1045-V	L-1045-V
22	WOODRUFF KEY	108093-01	108093-01	A-4333	-B	BUNA PACKING	N/A	L-1045-A	L-1045-A
23	CRANKSHAFT	115614-01	115614-01	115614-01	67	PLUNGER – GASKET	112712-01	L-1098	L-1098
24	O-RING	L-1022	L-1022	L-1022	-U	FUMIGANT	N/A	114769-01	114769-01
25	GREASE ZERK	115647-01	115647-01	115647-01	68	PLUNGER – WASHER	112695-01	L-1044-A	L-1044-A
26	SETTING SLEEVE	115718-01	115718-01	115618-01	69	PLUNGER	112700-91	103290-91	112816-91
27	BEARING	L-1007-A	L-1007-A	L-1007-A	70	PLUNGER – LOCKNUT	92125	L-1047	L-1047
28	GASKET – DRIVE SIDE	L-1006	L-1006	L-3002	71	VALVE COVER	116073-01	115703-01	115603-01
29	VENT PLUG	S-350	S-350	S-350	-S	STAINLESS	N/A	115703-01S	115603-01S
30	NAME PLATE	111958-01	111958-01	111958-01	72	NOT USED			
31	DRIVE SCREW	A-3557	A-3557	A-3557	73	3/8 X 1-1/2 HEX BOLT	90911	90911	90911
32	OIL PLUG	C-431-B	C-431-B	C-431-B	-S	STAINLESS	N/A	90654	90654
33	FLANGE COVER	115724-01	115724-01	115724-01	74	OUTBOARD CYL.	116072-01	115702-01	115602-01
34	5/16 X 1 HEX BOLT	90637	90637	90637	-S	STAINLESS	N/A	115702-01S	115602-01S
35	SETTING HUB	115627-01	115627-01	115627-01	75	1/2 HEX BOLT	90704	90704	90705
36	SCREW	A-368	A-368	A-368	-S	STAINLESS (2 BOLTS)	N/A	90693/90687	90693/90687
37	SNAP RING	115791-01	115791-01	115791-01	76	NOT USED			
38	3/8 SELF-LOCK NUT	A-3097	A-3097	A-3097	NOT USED				
39	SETTING POINTER	115628-01	115628-01	115628-01	77	NOT USED			
40	SETTING SCALE	115645-01	115645-01	115645-01	NOT USED				
41	3/8x2-1/4 CARR. BOLT	115646-01	115646-01	115646-01	NOT USED				
42	OIL SEAL	115622-01	115622-01	115622-01	78	NOT USED			
43	CRANKCASE	115720-01	115720-01	115620-01	NOT USED				
44	CROSSHEAD GASK.	115711-01	115711-01	115611-01	79	SPROCKET KEY	106493-01	106493-01	106493-01
45	1/2 HEX NUT	92029	92029	92029	A	RC50-18T SPRKT ASM	106532-01	106532-01	106532-01
-S	STAINLESS	N/A	92030	92030	-K	NO SPROCKET	NOT USED	NOT USED	NOT USED
46	GASKET- FLG COVER	L-1006	L-1006	L-1006	-R	RC40-18T SPRKT ASM	113907-01	113907-01	113907-01
47	HEX BOLT	90637	90637	90860	B	SPRKT. SPACER ASM	115624-91	115624-91	115624-91
48	CROSSHEAD GUIDE	116069-01	115700-01	115600-01	C	CONN. ROD ASM	L-1008-B	L-1008-B	113645-91
49	STUFF. BOX GASK.	116075-01	115610-01	115610-01	D	FLANGE COVER ASM	115725-91	115725-91	115725-91
-U	FUMIGANT	N/A	104828-02	104828-02	E	SET HUB ASM	115629-91	115629-91	115629-91
50	O-RING	116074-01	111943-01	111943-01	F	SET POINTER ASM	115630-91	115630-91	115630-91
51	PACKING 'V' SET	L-1113	L-1109	L-1109	G	GASKET KIT	116134	115788	115688
	@ CROSSHD GUIDE	USE 4 "V"s	N/A	N/A	-S	GASKET KIT - SS	N/A	115788-S	115688-S
-U	FUMIGANT	N/A	L-1109-U	L-1109-U	-U	GASKET KIT - FUM	N/A	115788-U	115688-U
52	PACKING WASHER	112694-01	L-1041	L-1041	H	OPERATORS KIT	115787	115787	115787
53	PACKING SPRING	112697-01	L-1063	L-1063	N/S	SLIDE CHART	115698-91	115698-91	115698-91
54	GREASE ZERK	H-30	H-30	H-30	N/S	SETTING WRENCH	115631-01	115631-01	115631-01

ZETA-120 - Exploded View Diagram and Parts List

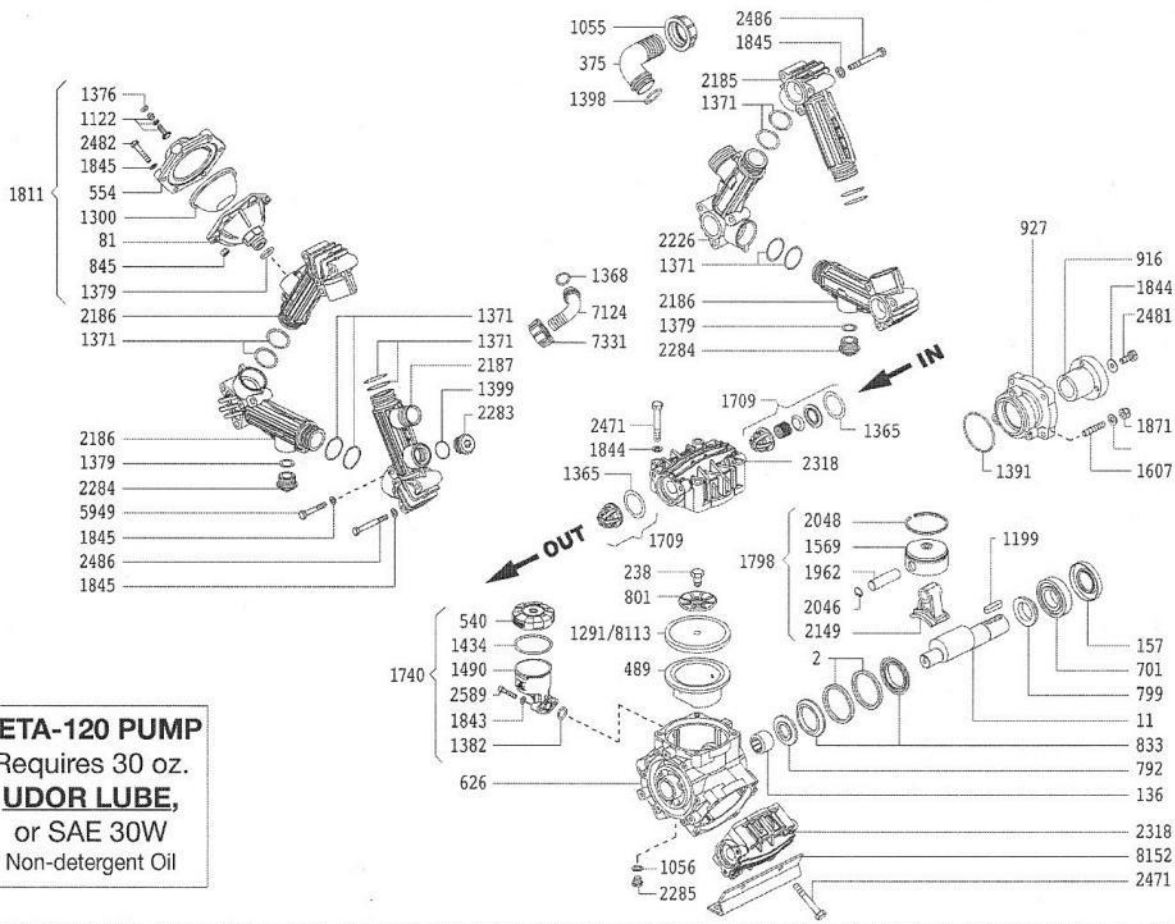

ZETA-120 PUMP
Requires 30 oz.
UDOR LUBE,
or SAE 30W
Non-detergent Oil

REF#	PART#	DESCRIPTION	QTY	REF#	PART#	DESCRIPTION	QTY
2	0001.02	Retainer Ring	2	1434	1101.D1	O-Ring	1
11	0002.60	Crank Shaft	1	1490	1203.27	Oil Reservoir	1
81	0003.15	Accumulator	1	1569	1205.08	Piston	3
136	0006.07	Bearing	1	1607	1206.22	Stud	3
157	0007.05	Seal	1	1709	6006.08	Valve Assembly	6
238	0102.03	Diaphragm Bolt	3	1740	6033.01	Oil Reservoir Assembly	1
375	0202.78	Suction Elbow	1	1798	6015.24	Piston Rod Assembly	3
489	0206.14	Piston Sleeve	3	1811	6031.09	Accumulator Assembly	1
540	0208.98	Oil Cap	1	1843	1403.07	Washer	2
557	0208.20	Accumulator Head	1	1844	1403.09	Washer	9
626	0209.A6	Crank Case	1	1845	1403.10	Washer	24
701	0214.05	Bearing	1	1962	1502.01	Connecting Rod Pin	3
792	0301.12	Washer	1	2046	1506.02	Snap Ring	6
799	0301.24	Washer	1	2048	1509.05	Piston Ring	3
801	0301.07	Retainer Washer	3	2149	1519.16	Connecting Rod	3
833	0302.52	Rod Spacer	2	2185	1601.36	Suction Manifold	1
845	0303.01	Nut	6	2186	1605.40	Manifold with 3/4" Female Port	3
871	0304.04	Lock Nut	3	2187	1605.39	Discharge Manifold	1
916	0501.62	Crank Shaft Flange	1	2226	1601.35	Suction Manifold	1
927	0501.79	FLANGE	1	2282	1603.50	Drain Plug	1
1055	0604.50	Barb Nut	1	2283	1603.87	Plug	1
1056	0605.49	Gasket	1	2284	1603.36	Plug	2
1122	0608.16	Air Valve Assembly	1	2285	1603.67	Plug	1
1199	0801.11	Key	1	2318	1604.E3	Head	3
1291	0903.02	Diaphragm (BUNA-N, Optional)	3	2471	1804.25	Bolt	12
*1300	0903.14	Accumulator Diaphragm	1	2481	1804.07	Bolt	1
*1365	1101.01	O-Ring	6	2482	1804.09	Bolt	6
1368	1101.04	O-Ring	1	2486	1804.79	Bolt	12
1371	1101.L5	O-Ring	12	2589	1805.31	Bolt	2
1376	1101.16	O-Ring	1	5949	1804.72	Bolt	6
1379	1101.04	O-Ring	1	7124	0253.05	Discharge Elbow	1
1382	1101.29	O-Ring	1	7331	0604.36	Discharge Nut	1
1391	1101.43	O-Ring	1	*8113	0903.34	Diaphragm (DESMOPAN, Standard)	3
1398	1101.42	O-Ring	1	8152	1202.96	Mounting Rails	2
1399	1101.51	O-Ring	1				

* Parts Included in Diaphragm Repair Kit - #8700.04. (Also available in Buna-N - #8700.11.)

KAPPA-40/41

KAPPA-30/40 PUMPS

Require 20 oz.
UDOR LUBE
or SAE 40W
Non-detergent Oil

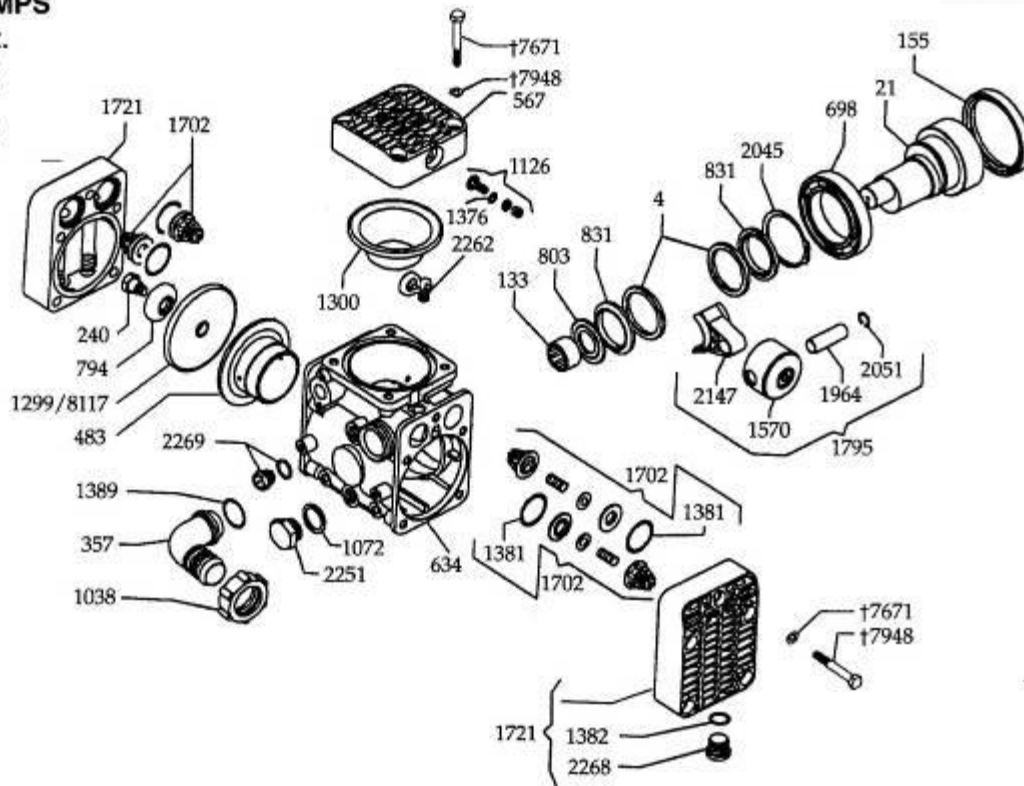

ITEM	PART NO.	DESCRIPTION	QTY	PRICE
4	0001.06	RETAINING RING	2	34.20
21	0002.71	CRANKSHAFT	1	378.63
133	0006.02	BEARING	1	64.58
155	0007.01	SEAL	1	39.86
240	0102.04	DIAPHRAGM BOLT	2	20.50
357	0202.18	INLET HOSE BARB	1	14.63
483	0206.08	PISTON SLEEVE	2	121.23
567	0208.34	ACCUMULATOR HEAD	1	88.79
634	0209.40	PUMP BODY	1	268.21
698	0214.01	BALL BEARING	1	220.73
794	0301.14	RETAINER WASHER	2	12.77
803	0301.30	WASHER	1	8.76
831	0302.50	SPACER	2	13.39
1038	0604.18	SUCTION NUT	1	12.46
1072	0605.09	GASKET	1	1.44
1126	0608.16	AIR VALVE ASSEMBLY	1	19.36
1299	0903.13	PISTON DIAPHRAGM	2	27.60
*1300	0903.14	ACCUMULATOR DIAPHRAGM	1	26.57
1376	1101.16	O'RING	1	2.37
*1381	1101.27	O'RING	4	2.58
1382	1101.29	O'RING	4	2.27
1389	1101.41	O'RING	1	2.37
1570	1205.07	PISTON	2	87.45
1702	6006.01	VALVE ASSEMBLY	4	30.59
1721	6017.06	HEAD ASSEMBLY	2	125.97
1795	6015.21	PISTON/ROD ASSEMBLY	2	149.97
1964	1502.03	CONNECTING ROD PIN	2	14.52

ITEM	PART NO.	DESCRIPTION	QTY	PRICE
2045	1506.01	SNAP RING	1	7.11
2051	1506.15	SNAP RING	4	1.65
2147	1519.18	CONNECTING ROD	2	48.93
2251	1603.02	PLUG	1	4.74
2262	1603.24	OIL PLUG	1	10.09
2268	1603.32	HEAD PLUG	4	7.42
2269	1603.33	OIL SIGHT GLASS	1	12.77
2602	1805.25	HEAD BOLT	14	2.68
7671	1403.09	WASHER	14	1.13
7948	1804.45	HEAD BOLT	14	3.91
*8117	0903.38	PISTON DIAPHRAGM	2	49.65

DIAPHRAGM REPAIR KIT 8700.02 \$100.01
BUNA-N REPAIR KIT 8700.12 \$90.64

KAPPA-55

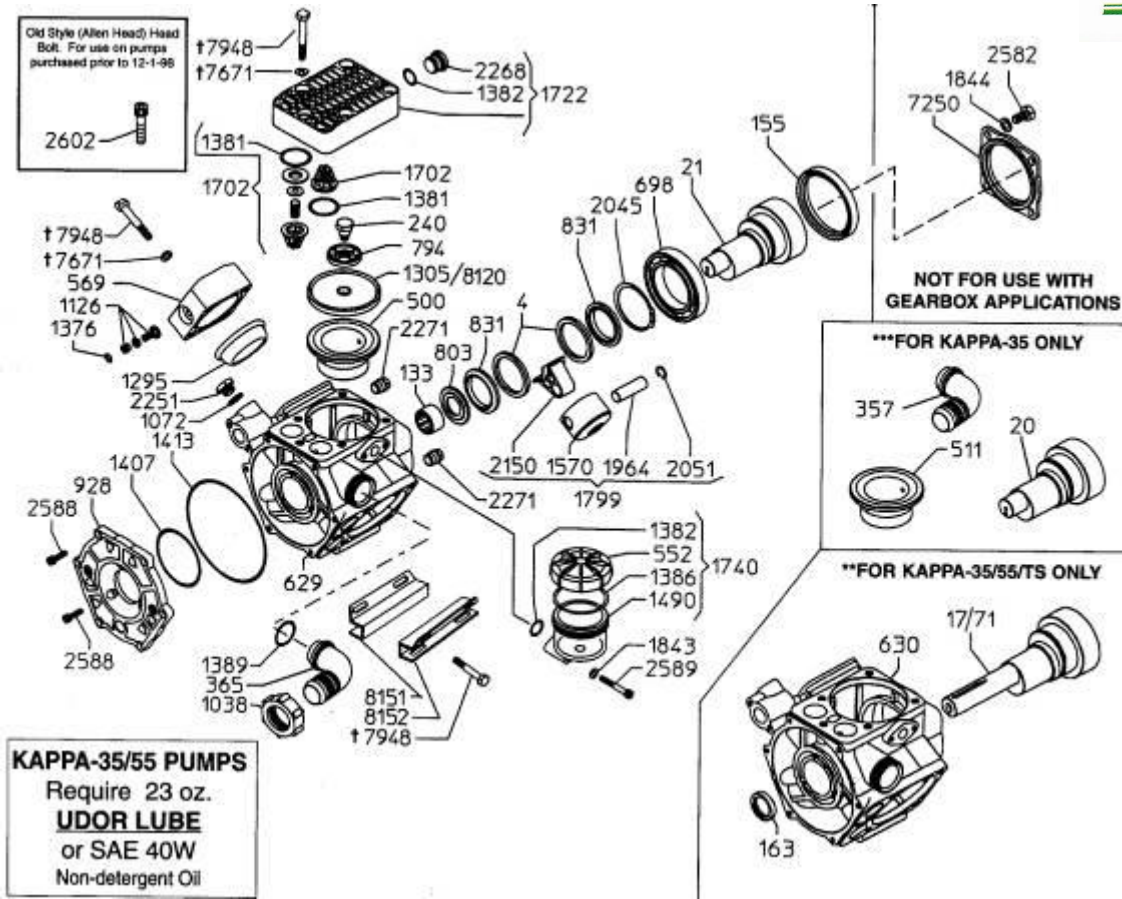

ITEM	PART NO.	DESCRIPTION	QTY	PRICE
4	0001.06	RETAINING RING	2	34.20
17	0002.72	CRANKSHAFT(KAPPA-55/TS)	1	527.98
***20	0002.70	CRANKSHAFT(KAPPA-35)	1	378.63
21	0002.71	CRANKSHAFT(KAPPA-55)	1	378.63
133	0006.02	BEARING	1	64.58
155	0007.01	SEAL	1	39.86
163	0007.19	SEAL(T.S.)	1	19.26
240	0102.04	DIAPHRAGM BOLT	3	20.50
***357	0202.18	SUCTION ELBOW(KAPPA-35)	1	14.63
365	0202.52	SUCTION ELBOW	1	18.54
500	0206.31	PISTON SLEEVE(KAPPA-55)	3	121.13
***511	0206.39	PISTON SLEEVE(KAPPA-35)	3	121.13
552	6033.01	OIL RESERVOIR CAP	1	65.10
569	0208.46	ACCUMULATOR HEAD	1	68.50
629	0209.44	PUMP BODY	1	436.72
630	0209.46	PUMP BODY(T.S.)	1	465.56
698	0214.01	BALL BEARING	1	220.73
794	0301.14	RETAINER WASHER	3	12.77
803	0301.30	SPACER	1	8.76
831	0302.50	SPACER	2	13.39
928	0501.85	BODY FLANGE	1	56.55
1038	0604.18	BARB NUT	1	12.46
1072	0605.09	ALUMINUM GASKET	1	1.44
1126	0608.16	AIR VALVE ASSEMBLY	1	19.36
*1295	0903.08	ACCUMULATOR DIAPHRAGM	1	17.82
1305	0903.43	PISTON DIAPHRAGM(BUNA-N)	3	27.60
1376	1101.16	O'RING	1	2.37
*1381	1101.27	O'RING	6	2.58
1382	1101.29	O'RING	7	2.27
1386	1101.68	O'RING	1	5.36
1389	1101.41	O'RING	1	2.37
1407	1101.62	O'RING	1	5.56
*DIAPHRAGM REPAIR KIT			8700.26	\$104.13

ITEM	PART NO.	DESCRIPTION	QTY	PRICE
1413	1101.87	O'RING	1	10.61
1490	6033.01	OIL RESERVIOR	1	65.10
1570	1205.07	PISTON	3	87.45
1702	6006.01	VALVE ASSEMBLY	6	30.59
1722	6017.13	HEAD ASSEMBLY	3	115.67
1740	6033.01	OIL RESERVIOR ASSY	1	65.10
1799	6015.27	PISTON/ROD ASSEMBLY	3	158.72
1843	1403.07	WASHER	2	1.13
1844	1403.09	WASHER	4	1.13
1964	1502.03	CONNECTING ROD PIN	3	14.52
2045	1506.01	SNAP RING	1	7.11
2051	1506.15	SNAP RING	6	1.65
2150	1519.18	CONNECTING ROD	3	48.93
2251	1603.02	PLUG	1	4.74
2268	1603.32	KAPPA HEAD PLUG	6	7.42
2271	1603.44	3/8" PLUG	2	4.33
2582	1805.04	BOLT-M10X20	4	2.27
2588	1805.21	BOLT-M6X22	9	1.75
2589	1805.26	BOLT-M6X45	2	1.96
2602	1805.25	HEAD BOLT(ALLEN HEAD-OLD STYLE)	19	2.68
7250	0501.02	SEAL RETAINER	1	15.55
+7671	1403.09	WASHER(USE W/7948 ONLY)	15	1.13
+7948	1804.45	HEAD BOLT(HEX HEAD-NEW STYLE)	19	3.91
*8120	0903.50	PISTON DIAPHRAGM(DESMPAN)	3	45.63
8151	1202.63	MOUNTING RAIL-RIGHT SIDE	1	52.84
8152	1202.64	MOUNTING RAIL-LEFT SIDE	1	52.84

***PARTS FOR KAPPA-35 ONLY
 +FOR USE WITH NEW STYLE HEADS AND PULSATION DAMPENER PURCHASED AFTER 12-1-98

DELTA-100

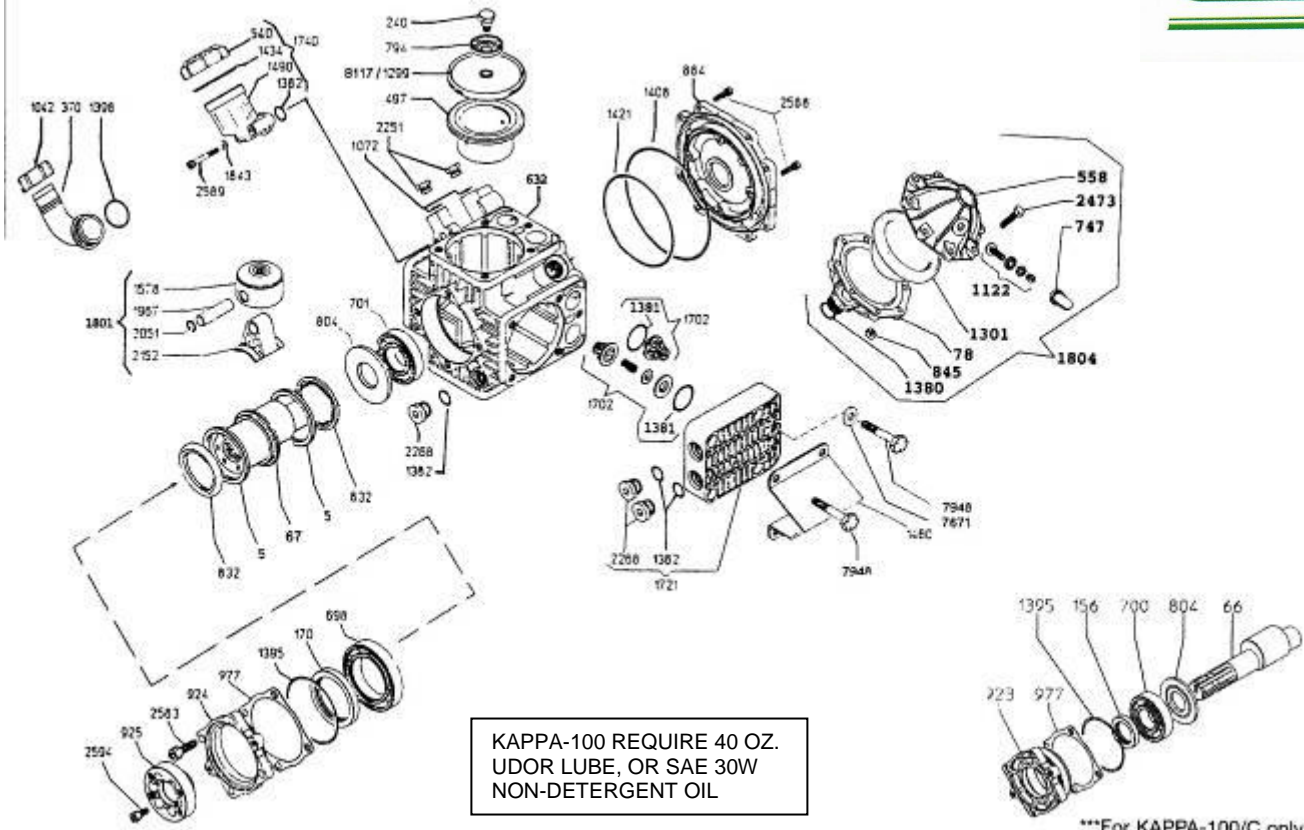

***For KAPPA-100/C only.

ITEM	PART NO.	DESCRIPTION	QTY	PRICE
5	0001.07	RETAINER RING	2	50.78
66/67	0002.56	CRANKSHAFT(100/C)	1	400.26
78	0003.10	PRESSURE ACCUMULATOR	1	239.78
***156	0007.02	SHAFT SEAL(100/C)	1	21.01
170	0007.27	SEAL	1	27.50
240	0102.04	DIAPHRAGM BOLT	4	20.50
497	0206.24	PISTON SLEEVE	4	132.05
552	6033.01	OIL RESERVOIR CAP	1	65.10
558	0208.21	ACCUMULATOR HEAD	1	216.71
632	0209.45	PUMP BODY	1	658.17
698	0214.01	BALL BEARING	1	220.73
***700	0214.04	BALL BEARING(100/C)	1	166.65
701	0214.05	BALL BEARING	1	121.23
747	0218.01	AIR VALVE CAP PROTECTOR	1	2.68
794	0301.14	RETAINER WASHER	4	12.77
804	0301.32	SPACER (2 FOR 100/C)	1	13.91
832	0302.51	WASHER	2	13.91
845	0303.01	NUT	8	1.65
871	0304.04	SELF-LOCKING NUT	2	2.27
884	0501.87	MANIFOLD COVER	1	84.15
***923	0501.71	FLANGE (100/C)	1	106.30
924	0501.69	FLANGE	1	8.86
925	0501.70	SHAFT ADAPTER	1	164.49
977	0602.05	GASKET	1	3.40
1042	0604.25	SUCTION NUT	1	17.10
1072	0605.09	ALUMINUM GASKET	2	1.44
1122	0608.16	AIR VALVE ASSEMBLY	1	19.36
1299	0903.13	PISTON DIAPHRAGM	4	27.60
*1301	0903.16	ACCUMULATOR DIAPHRAGM	1	38.93

ITEM	PART NO.	DESCRIPTION	QTY	PRICE
1380	1101.25	O'RING	1	2.37
**13811	1101.27	O'RING	8	2.58
1382	1101.29	O'RING	10	2.27
1386	1101.68	O'RING	1	5.36
1395	1101.48	O'RING	1	6.39
1398	1101.42	O'RING	1	2.58
1408	1101.63	O'RING	1	11.74
1421	1101.88	O'RING	1	9.48
1460	1202.37	MOUNTING RAIL	2	47.90
1490	6033.01	OIL RESERVOIR	1	65.10
1578	1205.18	PISTON	4	99.81
1702	6006.01	VALVE ASSEMBLY	8	30.59
1721	6017.06	HEAD ASSEMBLY	4	125.97
1740	6033.01	OIL RESERVOIR	1	65.10
1801	6015.29	PISTON/ROD ASSEMBLY	4	180.04
1804	6031.02	ACCUMULATOR ASSEMBLY	1	435.59
1843	1403.07	WASHER	2	1.13
1845	1403.10	WASHER	6	1.13
1967	1502.07	CONNECTING ROD PIN	4	24.93
2051	1506.15	SNAP RING	8	1.65
2152	1519.19	CONNECTING ROD	4	67.05
2251	1603.64	OIL PLUG	2	11.12
2268	1603.32	HEAD PLUG	9	7.42
2473	1804.54	BOLT, M8 X 40	8	1.96
2583	1805.05	BOLT	4	2.27
2588	1805.21	BOLT	12	1.75
2589	1805.26	BOLT	2	1.96
2593	1805.14	RAIL MTG HEAD BOLT(OS)	8	3.61
2594	1805.24	BOLT	6	1.75
2603	1805.12	HEAD BOLT, M10 X 50(OS)	12	2.68
+7671	1403.09	WASHER - HEAD BOLT(NS)	12	1.13
+7948	1804.45	HEAD BOLT - HEX HEAD(NS)	20	3.91
*8117	0903.38	DESMOPAN PISTON DIAPHRAGM	4	49.65

*DIAPHRAGM REPAIR KIT 8700.24 \$152.44
 BUNA-N REPAIR KIT 8700.23 \$127.10

KAPPA - 151



Require 84 oz. UDOR
LUBE, or SAE 40W
Non-detergent Oil

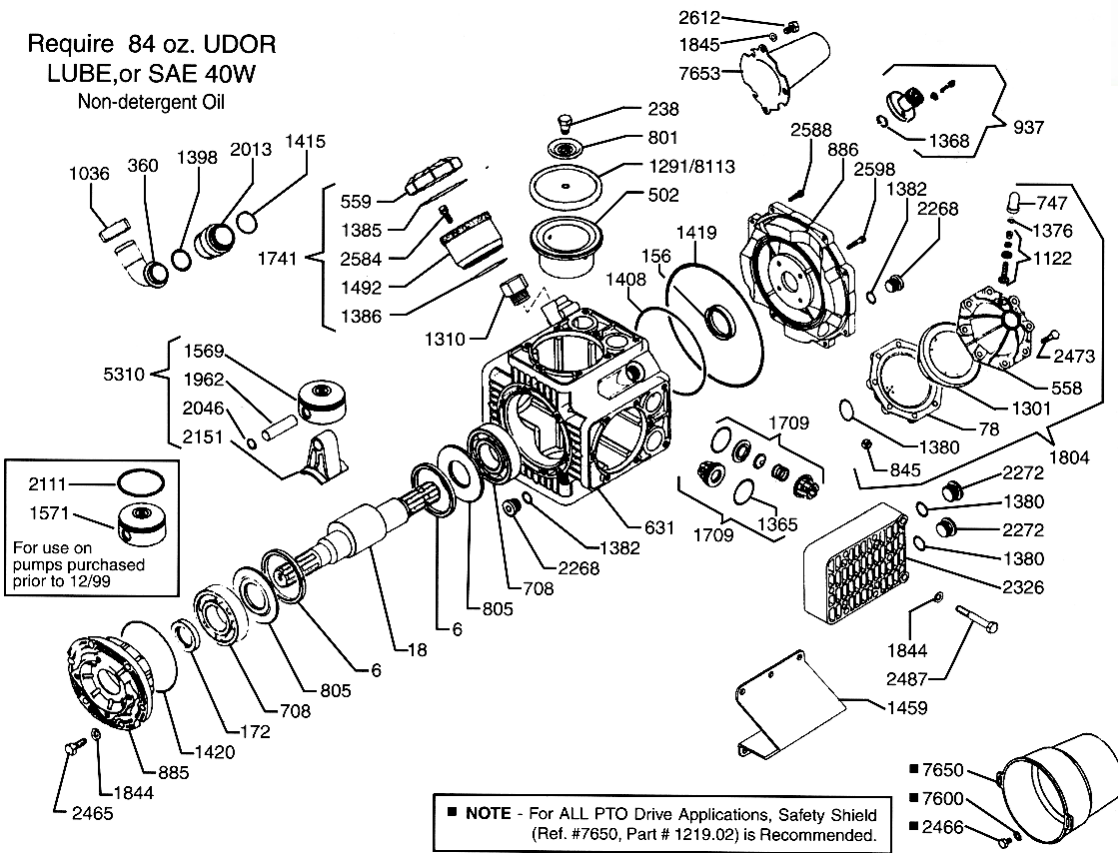

*DIAPHRAGM REPAIR KIT: 8700.22 \$197.25
DIAPHRAGM REPAIR KIT AVAILABLE IN BUNA-N: 8700.21 \$153.37

ITEM	PART NO.	DESCRIPTION	REQ'D	PRICE
6	0001.08	RETAINER RING	2	57.06
18	0002.65	CRANK SHAFT	1	587.51
78	0003.10	PRESSURE ACCUMULATOR	1	239.78
156	0007.02	SEAL	1	21.01
172	0007.34	SEAL	1	22.15
238	0102.03	DIAPHRAGM BOLT	4	24.00
360	0202.84	SUCTION ELBOW	1	84.15
502	0206.29	PISTON SLEEVE	4	181.59
558	0208.21	ACCUMULATOR HEAD	1	216.71
559	0208.22	OIL CAP	1	15.66
631	0209.33	PUMP BODY	1	1553.96
708	0214.16	BEARING	2	297.77
747	0218.01	AIR VALVE CAP	1	2.68
801	0301.07	RETAINER WASHER	4	15.76
805	0301.34	SPACER	2	68.80
845	0303.01	NUT	8	1.65
885	0501.81	BEARING RETAINER	1	201.26
886	0501.80	BODY FLANGE	1	277.38
937	0508.03/K	3/4" MNPT OUTLET	1	50.47
1036	0604.48	SUCTION BRASS NUT	1	64.58
1122	0608.16	AIR VALVE ASSEMBLY	1	19.36
1291	0903.02	BUNA-N DIAPHRAGM	4	29.87
*1301	0903.16	ACCUMULATOR DIAPHRAGM	1	38.93
1310	1001.04	3/4" ADAPTER FITTING	1	2.37
*1365	1101.01	O-RING	8	3.81
1368	1101.04	O-RING	1	2.37
1376	1101.16	O-RING	1	2.37
1380	1101.25	O-RING	9	2.37
1382	1101.29	O-RING	2	2.27
1385	1101.32	O-RING	1	6.49
1386	1101.68	O-RING	1	2.27
1398	1101.42	O-RING	1	2.58

ITEM	PART NO.	DESCRIPTION	REQ'D	PRICE
1408	1101.63	O-RING	1	11.74
1415	1101.77	O-RING	1	2.58
1419	1101.80	O-RING	1	20.60
1420	1101.71	O-RING	1	9.68
1459	1202.36	MOUNTING RAILS	2	54.18
1492	1203.30	OIL RESERVOIR	1	49.03
1569	1205.06	PISTON	4	102.90
1571	1205.08	PISTON	4	102.90
1709	6006.08	VALVE ASSEMBLY	8	40.07
1741	6033.02	OIL RESERVOIR ASSEMBLY	1	80.55
1804	6031.02	ACCUMULATOR ASSEMBLY	1	435.59
1844	1403.09	WASHER	26	1.13
1845	1403.10	WASHER	2	1.13
1962	1502.01	CONNECTING ROD PIN	4	20.81
2013	1504.04	NIPPLE	1	N/A
2046	1506.02	SNAP RING	8	1.65
2111	1509.05	PISTON RING	4	15.97
2151	1519.24	CONNECTING ROD	4	80.03
2268	1603.32	BODY PLUGS	2	7.42
2272	1603.40	HEAD PLUGS	8	7.83
2326	1604.51	HEAD	4	192.82
2465	1804.03	BOLT M10 x 30	6	
2466	1804.06	BOLT	2	
2473	1804.54	BOLT M8 x 40	8	1.96
2487	1804.25	BOLT M10 x 75	32	3.71
2584	1805.06	BOLT M6 x 20	3	1.75
2588	1805.21	BOLT M6 x 22	8	1.75
2598	1805.31	BOLT M6 x 30	4	1.65
2612	1805.47	BOLT	2	CALL
5310	6015.36	PISTON/ROD ASSEMBLY	4	228.56
7600	1403.36	WASHER	2	
7650	1219.02	PTO SAFETY SHIELD	1	31.00
7653	1219.15	THRU-SHAFT PROTECTOR	1	18.13
*8113	0903.34	DESMOPAN DIAPHRAGM	4	53.56



OMEGA-170/CC

Exploded View Diagram and Parts List

OMEGA-170/CC PUMP
 Requires 87 oz.
UDOR LUBE
 or SAE 30W
 Non-detergent Oil

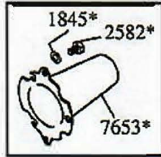

*Optional Thru-Shaft Protector

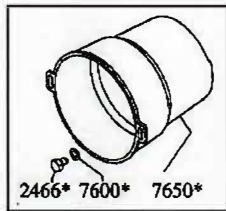
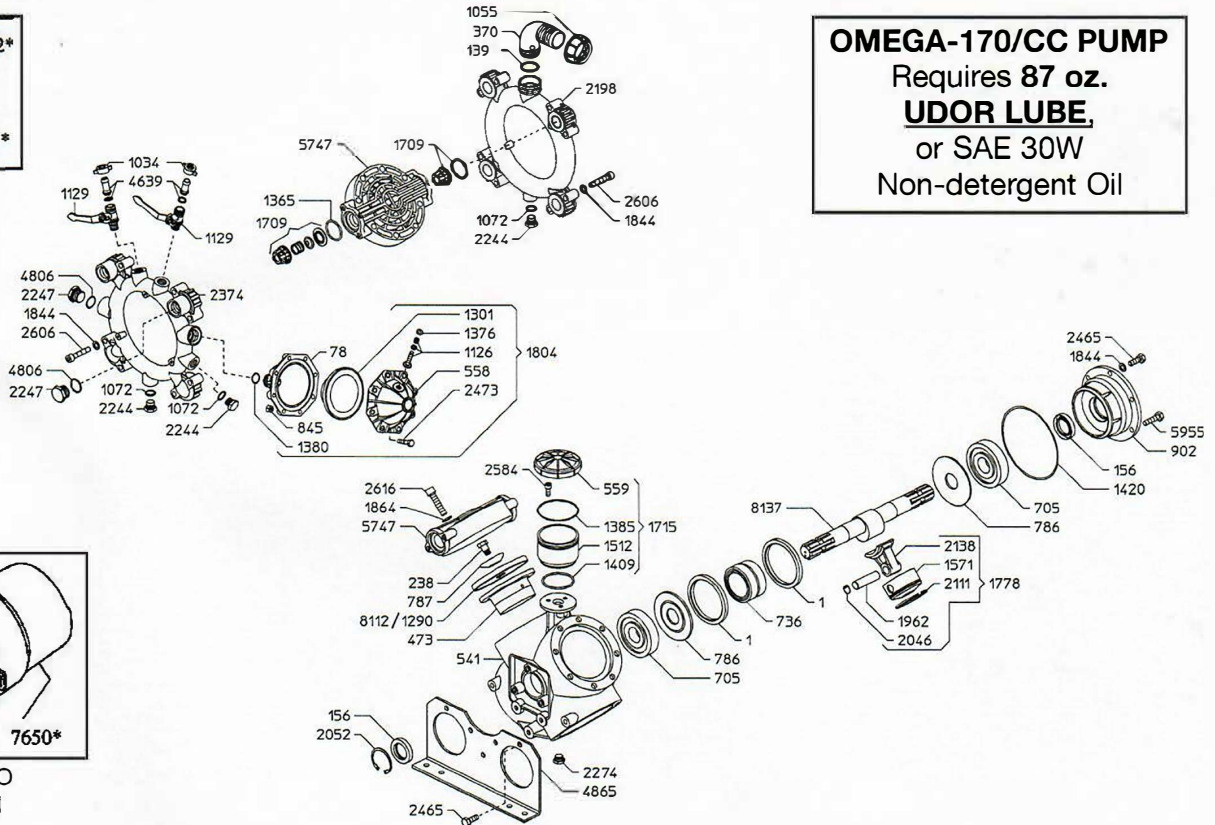

*Optional PTO Safety Shield

REF#	PART#	DESCRIPTION	QTY	REF#	PART#	DESCRIPTION	QTY
1	0001.01	Retainer Ring	2	1778	6015.01	Piston/Rod Assy.	4
78	0003.10	Lower Accumulator	1	1804	6031.02	Accumulator Assy.	1
156	0007.02	Shaft Seal	2	1844	1403.09	Washer	20
238	0102.03	Diaphragm Bolt	4	*1845	1403.10	Washer	3
370	0202.72	Suction Elbow	1	1864	1403.45	Washer	32
473	0206.49	Piston Sleeve	4	1962	1502.01	Wrist Pin	4
541	0209.92	Crankcase	1	2046	1506.02	Snap Ring	8
558	0208.21	Upper Accumulator	1	2052	1506.16	Snap Ring	1
559	0208.22	Oil Cap	1	2111	1509.05	Piston Ring	4
705	0214.11	Ball Bearing	2	2138	1519.03	Connecting Rod	4
736	0216.02	Needle Bearing	1	2198	1601.29	Suction Manifold	1
786	0301.02	Spacer	2	2244	1603.64	Plug	2
787	0301.03	Diaphragm Washer	4	2247	1603.74	Plug	2
845	0303.01	Nut	8	2274	1603.44	Drain Plug	1
902	0501.46	Bearing Flange	1	2374	1605.33	Discharge Manifold	1
1034	0604.09	Barb Nut	2	2465	1804.03	Bolt	9
1055	0604.50	Suction Nut	1	*2466	1804.06	Bolt	3
1072	0605.09	Gasket	2	2473	1804.54	Bolt	8
1126	0608.16	Air Valve Assy.	1	*2582	1805.04	Bolt	3
1129	0608.46	Ball Valve Left	2	2584	1805.06	Bolt	3
1290	0903.01	Piston Diaphragm BUNA optional	4	2606	1805.29	Manifold Bolt	16
**1301	0903.16	Accumulator Diaphragm	1	2616	1805.38	Head Bolt	32
**1365	1101.01	O-Ring	8	4639	0202.19	Discharge Barb	2
1376	1101.16	O-Ring	1	4806	1101.G3	O-Ring	2
1380	1101.25	O-Ring	1	4865	1202.83	Pump Rail	2
1385	1101.32	O-Ring	1	5747	1604.B7	Pump Head	4
1398	1101.42	O-Ring	1	5955	1804.23	Bolt	2
1409	1101.68	O-Ring	1	*7600	1403.36	Washer	3
1420	1101.71	O-Ring	1	*7650	1219.02	PTO Safety Shield *optional	1
1512	1203.30	Oil Reservoir	1	*7653	1219.15	Shaft Protector Thru Shaft *optional	1
1571	1205.08	Piston	4	**8112	0903.33	Diaphragm DESMOPAN Standard	4
1709	6006.08	Valve Assy.	8	8137	0002.A6	Crankshaft	1
1715	6033.02	Oil Reservoir Assy.	1				

* Parts Included in Diaphragm Repair Kit - #8700.07. (Also available in BUNA-N - #8700.18.)

OMEGA-170/CC



OMEGA 140/CC



*Optional Thru-Shaft Protector

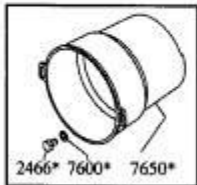

*Optional PTO Safety Shield

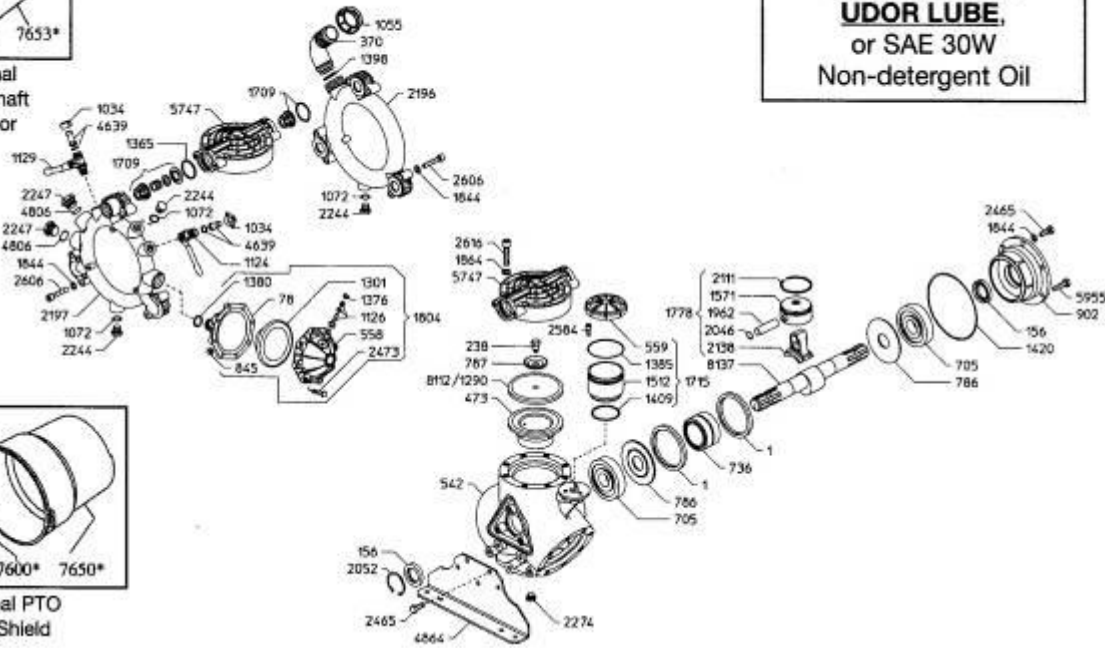

OMEGA-140/CC PUMP
 Requires 87 oz.
UDOR LUBE,
 or SAE 30W
 Non-detergent Oil

ITEM	PART NO.	DESCRIPTION	REQ'D	PRICE
1	0001.01	RETAINER RING	2	70.04
78	0003.12	LOWER ACCUMLATOR	1	239.78
156	0007.02	SHAFT SEAL	2	21.01
238	0102.03	DIAPHRAGM BOLT	3	24.00
370	0202.78	SUCTION ELBOW	1	24.21
473	0206.49	PISTON SLEEVE	3	181.59
558	0208.21	UPPER ACCUMLATOR	1	216.71
542	0209.91	PUMP BODY	1	
559	0208.22	OIL CAP	1	15.66
705	0214.11	BALL BEARING	2	382.95
736	0216.02	NEEDLE BEARING	1	507.28
786	0301.02	SPACER	2	121.23
787	0301.03	DIAPHRAGM WASHER	3	12.77
845	0303.01	NUT	8	1.65
902	0501.46	BEARING FLANGE	1	303.44
1034	0604.09	BARB NUT	2	8.86
1055	0604.50	SUCTION NUT	1	17.10
1072	0605.09	GASKET	2	1.44
1124	0608.45	BALL VALVE RIGHT	1	51.81
1126	0608.16	AIR VALVE ASSY	1	19.36
1129	0608.46	BALL VALVE LEFT	1	51.81
1290	0903.01	PISTON DIAPHRAGM	3	38.21
**1301	0903.16	ACCUMULATOR DIAPHRAGM	1	38.93
**1365	1101.01	O'RING	6	3.81
1376	1101.16	O'RING	1	2.37
1380	1101.25	O'RING	1	2.37
1385	1101.32	O'RING	1	6.49
1398	1101.42	O'RING	1	2.58
1409	1101.68	O'RING	1	5.36
1420	1101.71	O'RING	1	9.68
1512	1203.30	OIL RESERVOIR	1	49.03
1571	1205.08	PISTON	3	102.90
1709	6006.08	VALVE ASSY	6	40.07

ITEM	PART NO.	DESCRIPTION	REQ'D	PRICE
1715	6033.02	OIL RESERVOIR ASSY.	1	80.55
1778	6015.01	PISTON/ROD ASSY.	3	229.07
1804	6031.02	ACCUMULATOR	1	435.59
1844	1403.09	WASHER	16	1.13
*1845	1403.10	WASHER	3	1.13
1864	1403.45	WASHER	24	1.13
1962	1502.01	WRIST PIN	3	20.81
2046	1506.02	SNAP RING	6	1.65
2052	1506.16	SNAP RING	1	4.53
2111	1509.05	PISTON RING	3	15.97
2138	1519.03	CONNECTING ROD	3	83.02
2196	1601.28	SUCTION MANIFOLD	1	379.66
2197	1605.32	DISCHARGE MANIFOLD	1	381.31
2244	1603.64	PLUG	2	
2247	1603.74	HEAD	2	12.88
2465	1804.03	BOLT	8	2.06
*2466	1804.06	BOLT	3	1.96
2274	1603.44	DRAIN PLUG	1	4.33
*2582	1805.04	BOLT	3	2.27
2584	1805.06	BOLT	3	1.75
2606	1805.29	MANIFOLD BOLT	12	2.58
2616	1805.38	HEAD BOLT	24	2.58
4639	0202.19	DISCHARGE BARB	2	9.68
4806	1101.G3	O'RING	2	2.37
4864	1202.82	PUMP RAIL	2	58.81
5747	1604.B7	PUMP HEAD	3	303.03
5955	1804.23	BOLT	2	2.06
*7600	1403.36	WASHER	3	1.96
*7650	1219.02	PTO SAFETY SHIELD*OPT	1	31.00
*7653	1219.15	SHAFT PROTECTOR THRU SHAFT*OPT	1	18.13
**8112	0903.33	DIAPHRAGM DESMOPAN STD.	3	64.99
8137	0002.A6	CRANKSHAFT	1	

*DIAPHRAGM REPAIR KIT 8700.06 \$187.77

Revised 5-20-2008

PND 3.0/15-ZA

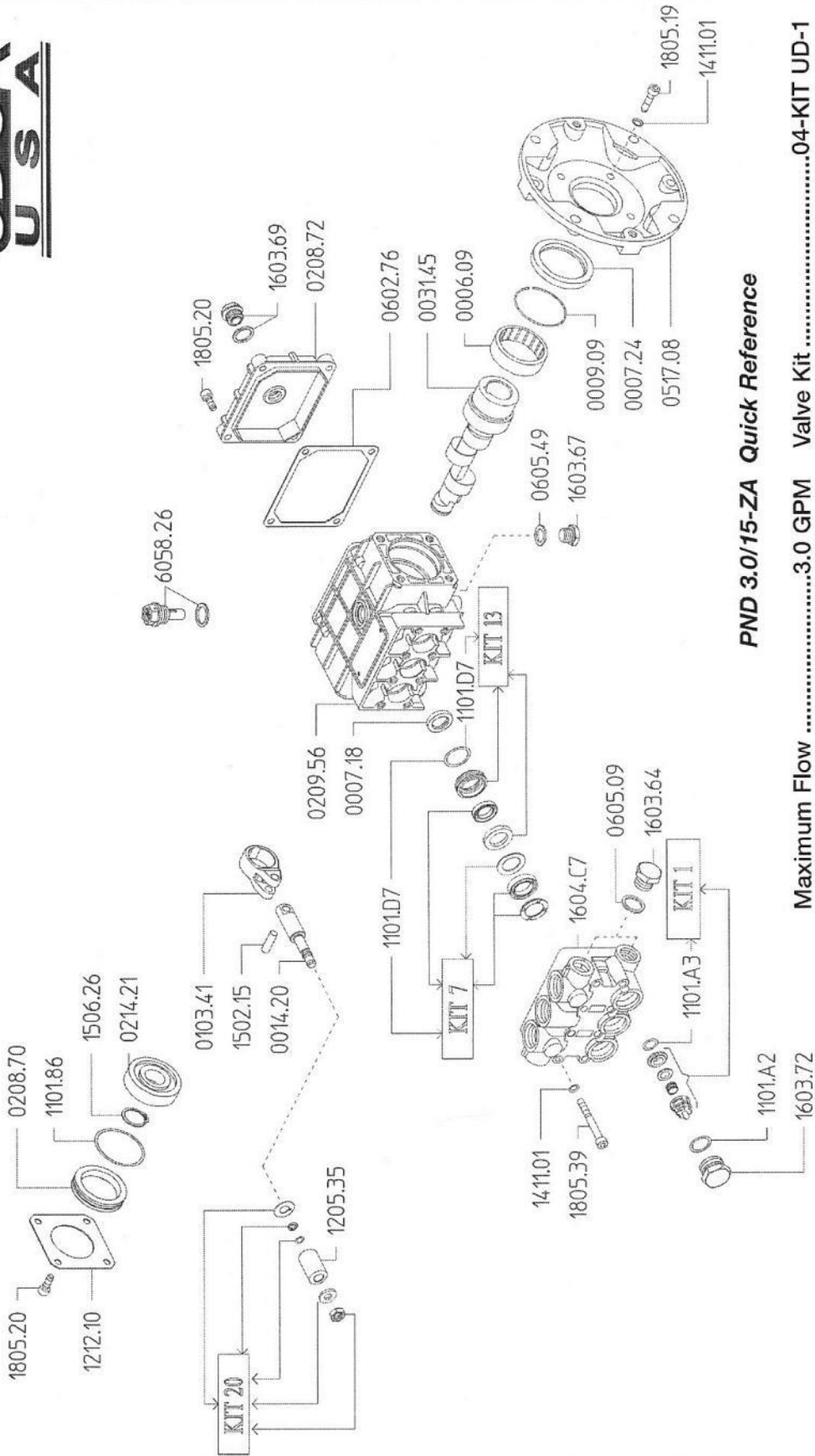
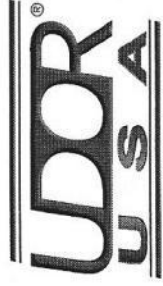

PND 3.0/15-ZA Quick Reference

Maximum Flow	3.0 GPM	Valve Kit	04-KIT UD-1
Maximum Pressure	1500 PSI	Seal Kit	04-KIT UD-7
Rated Pump Speed	1750 RPM	Brass Kit	04-KIT UD-13
Oil Capacity	12 oz. UDOR LUBE or SAE 30W Non-Detergent Oil	Plunger Bolt Kit	04-KIT UD-20
		Plunger Part #	1205.35
		Plunger Diameter	15 MM

PND 3.0/20-Z

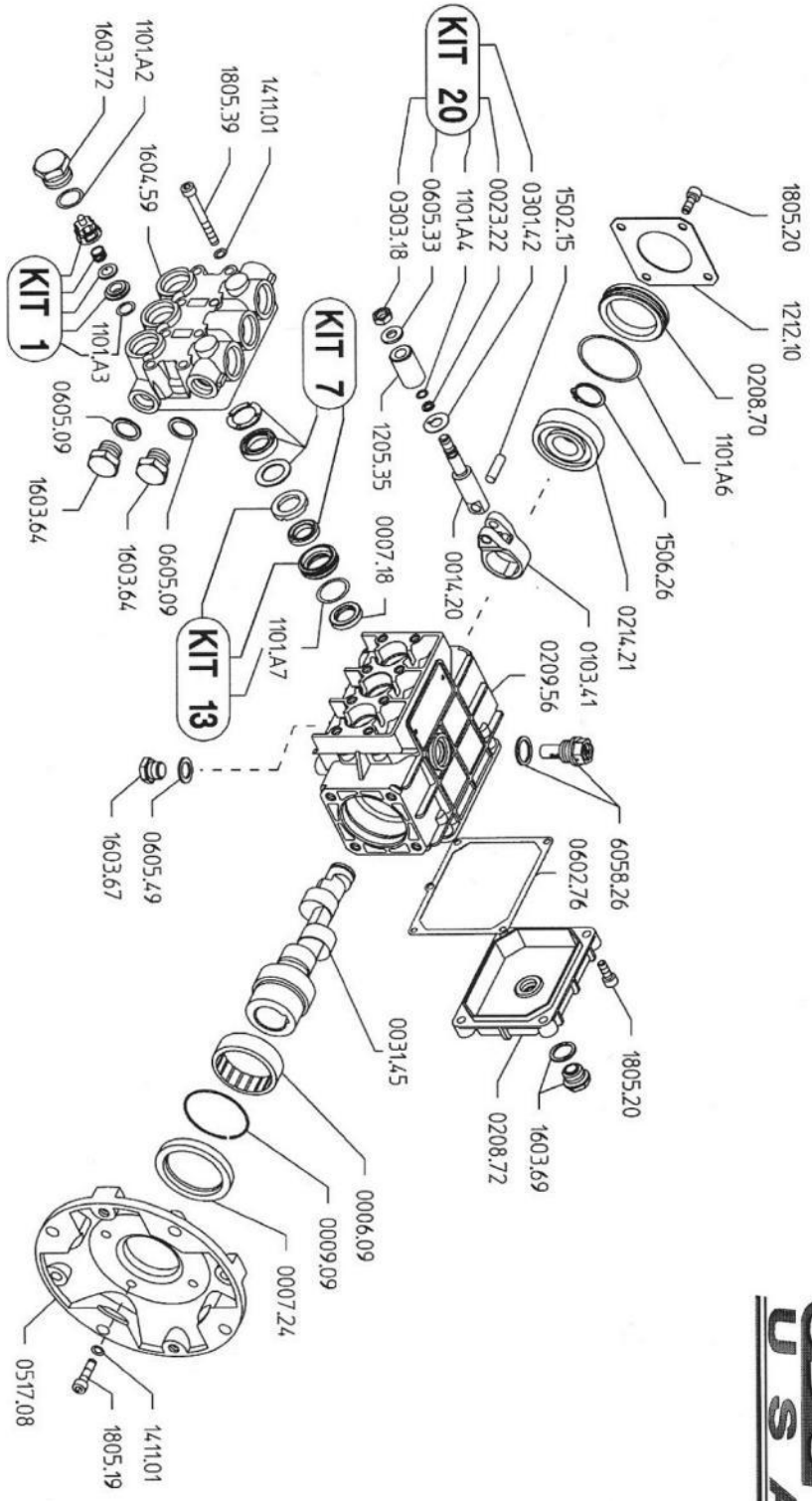
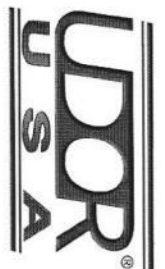

PND 3.0/20-Z Quick Reference

Maximum Flow	3.0 GPM	Valve Kit	04-KIT UD-1
Maximum Pressure	2000 PSI	Seal Kit	04-KIT UD-7
Rated Pump Speed	1750 RPM	Brass Kit	04-KIT UD-13
Oil Capacity	12 oz. UDOR LUBE or SAE 30W	Plunger Bolt Kit	04-KIT UD-20
		Plunger Part #	04-1205.35
		Plunger Diameter	15 MM

PND 3.0/20-Z

UDOR 6005.31 & 6005.31/LP CONTROL UNIT

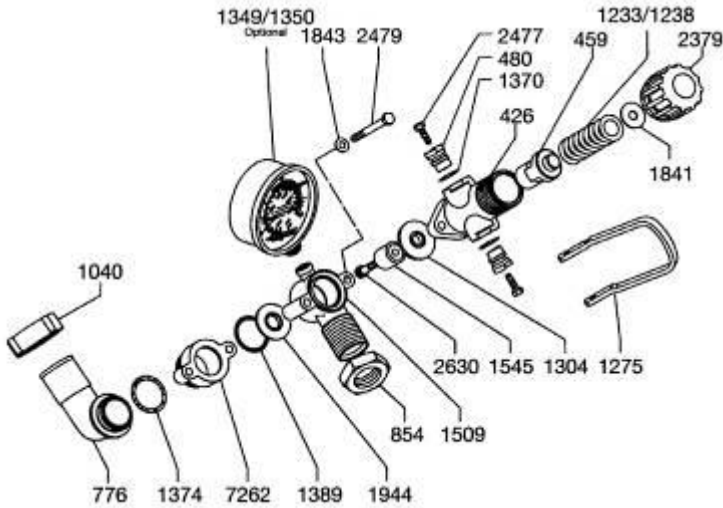

ITEM	PART NO.	DESCRIPTION	QTY	PRICE
426	0204.40	VALVE BODY	1	82.81
459	0205.10	VALVE CYLINDER	1	23.69
460	0205.11	VALVE CYLINDER CAM	2	19.67
776	0254.04	BY-PASS HOSE BARB	1	10.71
854	0303.41	NUT	1	11.43
1040	0604.26	BY-PASS NUT	1	9.48
1233	0901.24	SPRING	1	10.09
1238	0901.47	SPRING	1	10.09
1275	0902.25	HANDLE	1	10.20
*1304	0903.26	DIAPHRAGM	1	6.39
1349	GG350	GAUGE	1	39.86
1350	GG1000	GAUGE - OPT	1	39.86
*1370	1101.06	O'RING	2	2.27
1374	1101.12	O'RING	1	2.27
*1389	1101.41	O'RING	1	2.37
1509	1203.47	R.V. BODY	1	92.60
*1545	1204.19	STEEL POPPET	1	23.90
1841	1403.06	WASHER	1	1.44
1843	1403.07	WASHER	2	1.13
*1944	1501.37	SEAT	1	43.47
2379	1801.17	ADJUSTMENT KNOB	1	15.55
2477	1804.67	BOLT	2	1.44
2479	1804.74	BOLT	2	2.06
*2630	1810.01	BOLT-SS	1	5.25
262	0508.07	BY-PASS FLANGE	1	47.69
*REPAIR KIT			8701.25	\$66.44

6010.24 & 6010.24/LP CONTROL UNIT

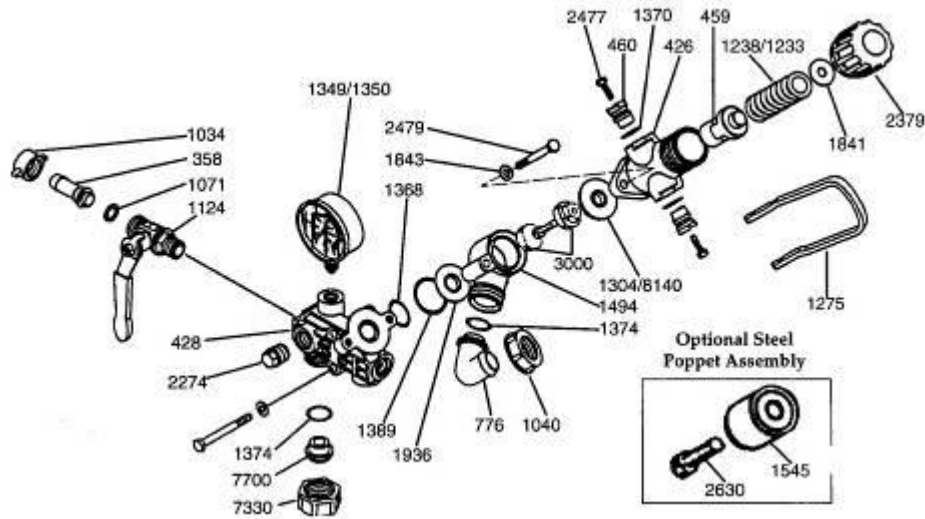

ITEM	PART NO.	DESCRIPTION	QTY	PRICE
358	0202.19	1/2" HOSE BARB	2	9.68
426	0204.40	VALVE BODY	1	82.81
428	0204.48	MAIN BODY	1	111.24
459	0205.10	VALVE CYLINDER	1	23.69
460	0205.11	VALVE CYLINDER CAM	2	19.67
776	0254.04	BYPASS ELBOE HOSE BARB	1	10.71
1034	0604.09	DISCHARGE BARB NUT	2	8.86
1040	0604.26	BYPASS BARB NUT	1	9.48
1071	0605.05	GASKET	2	1.65
1124	0608.45	BALL VALVE	2	51.81
1233	0901.24	SPRING	1	10.09
1238	0901.47	300 PSI SPRING 24/LP	1	10.09
1275	0902.25	DUMP VALVE LEVER	1	10.20
*1304	0903.26	DIAPHRAGM	1	6.39
1349	GG350	GAUGE (24/LP)	1	39.86
1350	GG1000	GAUGE	1	39.86
*1368	1101.04	O'RING	1	2.37

ITEM	PART NO.	DESCRIPTION	QTY	PRICE
*1370	1101.06	O'RING	2	2.27
1374	1101.12	O'RING	2	2.27
*1389	1101.41	O'RING	1	2.37
1494	1203.33	R.V. BODY	1	34.81
1545	1204.19	STEEL POPPET(OPT)	1	23.90
1841	1403.06	WASHER	1	1.44
1843	1403.07	WASHER	4	1.13
1936	1501.23	SEAT	1	28.43
2274	1603.44	PLUG	2	4.33
2379	1801.17	ADJUSTMENT KNOB	1	15.55
2477	1804.67	BOLT	2	1.44
2479	1804.74	BOLT	2	2.06
2630	1810.01	BOLT, SS (OPT)	1	5.25

7330	0604.29	NUT	1	7.00
7700	1603.22	PLUG	1	1.96
8140	0903.42	DIAPHRAGM, VITON (OPT)	1	60.46

*REPAIR KIT (URETHANE POPPET) 8701.10 \$66.44
 REPAIR KIT (STEEL POPPET) 8701.02 \$66.44

ZETA-170/C & ZETA-170/CC - Exploded View Diagram and Parts List

ZETA-170 PUMPS
 Require 44 oz.
UDOR LUBE,
 or SAE 30W
 Non-detergent Oil

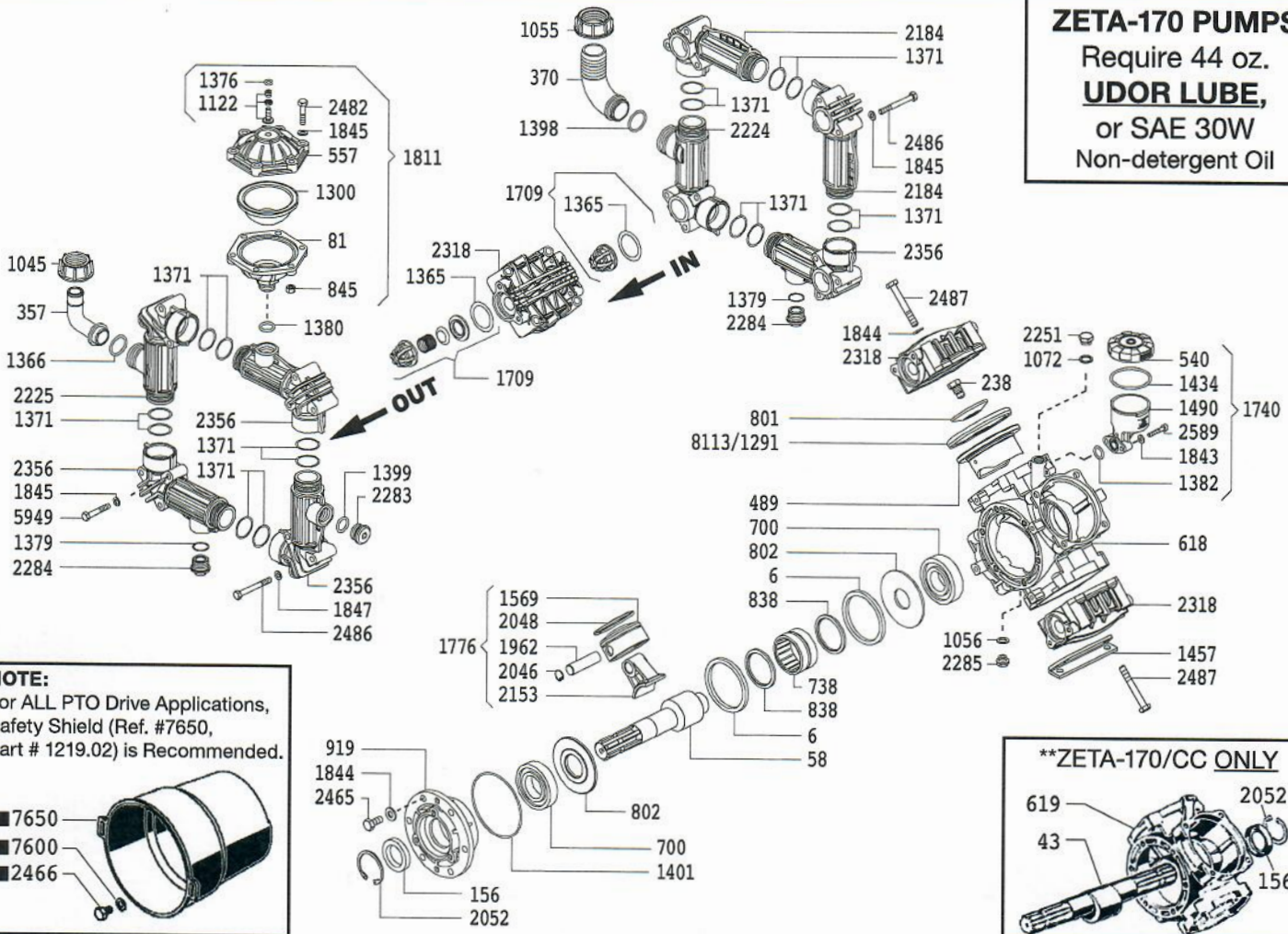

NOTE:
 For ALL PTO Drive Applications,
 Safety Shield (Ref. #7650,
 Part # 1219.02) is Recommended.

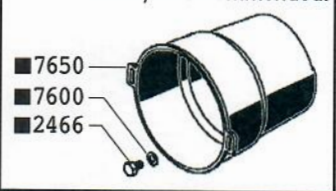

****ZETA-170/CC ONLY**

REF#	PART#	DESCRIPTION	QTY	REF#	PART#	DESCRIPTION	QTY
6	0001.08	Retainer Ring	2	1434	1101.D1	O-Ring	1
**43	0002.29	Crankshaft (ZETA-170/CC)	1	1457	1202.97	Mounting Rail	2
58	0002.46	Crankshaft (ZETA-170/C)	1	1490	1203.27	Oil Reservoir	1
81	0003.15	Pressure Accumulator	1	1569	1205.08	Aluminum Piston	4
156	0007.02	Seal (Qty. 2 for ZETA-170/CC)	1	1709	6006.08	Valve Assembly	8
238	0102.03	Diaphragm Bolt	4	1740	6033.01	Oil Reservoir Assembly	1
357	0202.18	Discharge Elbow	1	1776	6015.61	Piston & Rod Assembly	4
370	0202.78	Suction Elbow	1	1811	6031.09	Accumulator Assembly	1
489	0206.14	Piston Sleeve	4	1843	1403.07	Washer	2
540	0208.98	Oil Reservoir Cap	1	1844	1403.09	Washer	18
557	0208.20	Accumulator Head	1	1845	1403.10	Washer	30
618	0209.A8	Pump Body (ZETA-170/C)	1	1962	1502.01	Connecting Rod Pin	4
**619	0209.A9	Pump Body, T.S. (ZETA-170/CC)	1	2046	1506.02	Snap Ring	8
700	0214.04	Ball Bearing	2	2048	1509.05	Piston Ring	4
738	0216.07	Roller Bearing	1	**2052	1506.16	Snap Ring	2
801	0301.07	Retainer Washer	4	2153	1519.35	Connecting Rod	4
802	0301.28	Washer	2	2184	1601.38	Manifold	2
838	0302.59	Spacer Ring	2	2224	1601.37	Suction Manifold	1
845	0303.01	Hex Nut	6	2225	1605.41	Discharge Manifold	1
919	0501.L3	Bearing Flange	1	2251	1603.02	Oil Plug	1
1045	0604.32	Barb Nut	1	2282	1603.50	Drain Plug	1
1055	0604.50	Barb Nut	1	2283	1603.87	Plug	1
1056	0605.49	Gasket	1	2284	1603.36	Plug	2
1072	0605.09	Aluminum Gasket	1	2285	1603.67	Plug	1
1122	0608.16	Air valve Assembly	1	2318	1604.E3	Head	4
1291	0903.02	Piston Diaphragm, BUNA-N Optional	4	2356	1605.42	Manifold with 3/4" FNPT Port	4
**1300	0903.14	Accumulator Diaphragm	1	2465	1804.03	Bolt	6
*1365	1101.01	O-Ring	8	■ 2466	1804.06	Bolt	3
1366	1101.02	O-Ring	1	2482	1804.09	Bolt	6
1371	1101.L6	O-Ring	16	2486	1804.79	Bolt	16
1376	1101.16	O-Ring	1	2487	1804.25	Bolt	16
1379	1101.04	O-Ring	2	2589	1805.31	Bolt	2
1380	1101.25	O-Ring	1	■ 7600	1403.36	Washer	3
1382	1101.29	O-Ring	1	■ 7650	1219.02	PTO Safety Shield optional	1
1398	1101.42	O-Ring	1	*8113	0903.34	Piston Diaphragm, DESMOPAN Standard	4
1399	1101.51	O-Ring	1	5949	1804.72	Bolt	8
1401	1101.58	O-Ring	1				

HYPRO/SHURFLO PUMPS

8000-543-236

ITEM	PART NO.	DESCRIPTION	PRICE
1	94-380-02	COMPLETE PUMPHEAD - 60 PSI INCLUDES ITEM #2 THROUGH #7	142.42
2	94-375-05	SWITCH ASSEMBLY - 60 PSI	38.57
3A	94-374-05	VITON, 1-WAY CHECK VALVE	14.02
4	94-379-00	UPPER HOUSING - FEMALE NPT - POLY	23.66
5B	94-390-05	VALVE ASSEMBLY - VITON	46.39
**6	94-395-05	DIAPHRAGM KIT - VITON	63.89
	94-395-06	DIAPHRAGM KIT - SANTOPRENE	23.38
**7	94-385-03	LOWER HOUSING - DRIVE ASSEMBLY 3.0	28.94
8	NLA		
10	94-385-32	SOLID DRIVE ASSY KIT	57.34

8000-543-236

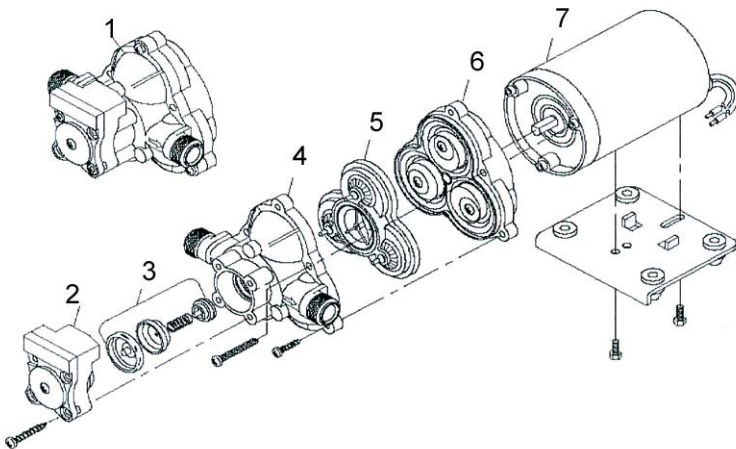
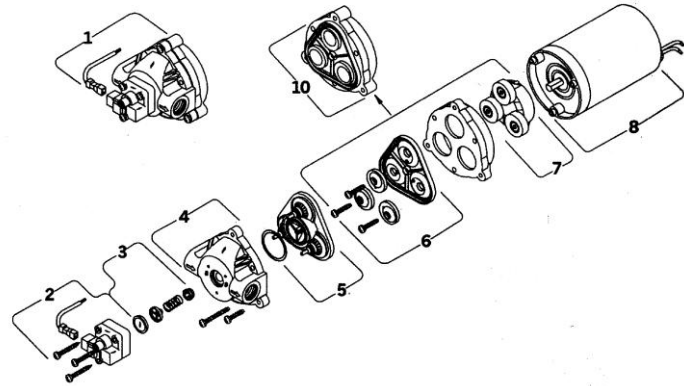

2088 SERIES

2088-343-135

ITEM	PART NO.	DESCRIPTION	PRICE
1	94-236-11	COMPLETE PUMP HEAD ASSY	164.90
2	94-230-36	SWITCH ASSY	31.77
3	94-237-05	CHECK VALVE ASSY	27.56
4	94-231-30	UPPER HOUSING	17.87
5	94-232-05	BYPASS/NON BYPASS VALVE ASSY	60.78
6	94-238-03	DRIVE/IMPELLER DIAPHRAGM ASSY	41.75
7	NLA		

2088-313-145

ITEM	PART NO.	DESCRIPTION	PRICE
1	94-236-15	COMPLETE PUMP HEAD ASSY	194.35
2	94-230-55	SWITCH ASSY	37.78
3	94-237-05	CHECK VALVE ASSY	27.56
4	94-231-30	UPPER HOUSING	17.87
5	94-232-05	BYPASS/NON BYPASS VALVE ASSY	60.78
6	94-238-03	DRIVE/IMPELLER DIAPHRAGM ASSY	41.75
7			



FMC-HYD-204, 210, & 310 PUMPS

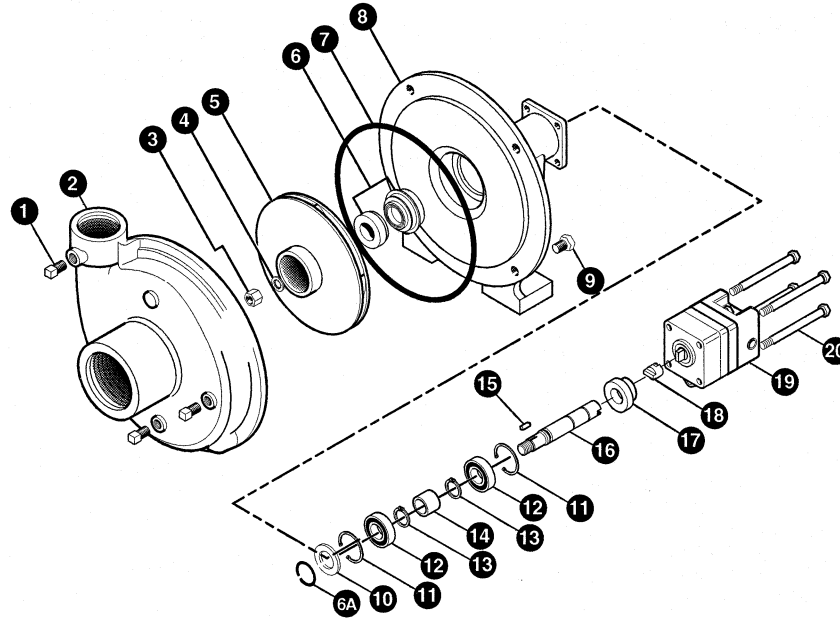

ITEM	PART NO.	DESCRIPTION	REQ'D	PRICE
1	BAC-53 41120	PIPE PLUG PIPE PLUG, STAINLESS STEEL OPTIONAL	3 3	0.51 5.10
2	BAC-12	VOLUTE, 1 1/4" X 1"	1	255.00
3	BAC-23-A	NUT, 3/8" NF, CAD PLATED	1	2.55
4	BAC-24-HYD-SS	WASHER, 3/8" STAR, STAINLESS STEEL	1	1.55
5	BAC-26-HYD-VALOX BAC-26-HYD-CI	IMPELLER, VALOX, KEYWAY IMPELLER, CAST IRON, KEYWAY OPTIONAL	1 1	92.00 209.00
*6	BAC-7V BAC-7SC	SEAL, MECHANICAL, VITON (INCLUDES 40160) SEAL, MECHANICAL, SILICON CARBIDE (INCLUDES 40160) OPTIONAL	1 1	51.00 173.00
6A	40160	RECOMMENDED FOR CAPROL AND OTHER ABRASIVE CHEMICALS O-RING, SHAFT SEAL	1	1.00
*7	BAC-4	GASKET, 4 HOLE (OBSOLETE 1996)	1	4.10
*7	BAC-4A	O-RING, BODY SEAL	1	8.15
8	BAC-14-HYD BAC-14-HYD-300	MOUNTING FRAME (FOR -200 SERIES HYDRAULIC MOTORS) MOUNTING FRAME (FOR -310 HYDRAULIC MOTOR)	1 1	326.00 347.00
9	40950 40930	CAP SCREW, 3/8" NC X 3/4" HEX HEAD CAP SCREW, 3/8" NC X 3/4" HEX HEAD, STAINLESS STEEL OPTIONAL	4 4	0.55 2.55
10	BAC-54	SLINGER	1	1.55
11	BAC-33	SNAP RING, INTERNAL, BAC-14 MOUNTING FRAME	2	2.05
12	BAC-37	BALL BEARING, SEALED, BAC-6 SHAFT	2	20.00
13	BAC-32	SNAP RING, EXTERNAL, BAC-6 SHAFT	2	0.55
14	BAC-32-S	SPACER FOR BAC-6 SHAFT	1	6.10
15	BACH-25	KEY, 1/8" X 1/8" X 1/2"	1	1.05
16	BAC-6-HYD-SS S200	SHAFT, 5/8" DIAMETER, KEYWAY AND TANG SLOT, SS SEAL SUPPORT SPACER FOR 200 SERIES HYD MOTOR WITH -L SEAL	11 1	128.00 10.00
18	BAC-76-HYD	COUPLING FOR HYDRAULIC MOTOR	1	29.00
19	BAC-75-HYD-204 BAC-75-HYD-210 BAC-75-HYD-310	HYDRAULIC MOTOR, 4 GPM HYDRAULIC MOTOR, 8 GPM HYDRAULIC MOTOR, 16 GPM	1 1 1	632.00 66800 1000.00
20	41330	CAP SCREW, 5/16" N.C. X 3/4" HEX HEAD (FOR 310 MOTOR)	4	0.55
*	RK-FMC	REPAIR KIT FOR FMC SERIES		60.70
	RK-BAC-75-HYD	REPAIR KIT FOR 204 AND 210 MOTOR		101.20
	RK-BAC-75-HYD-L	REPAIR KIT FOR 204 AND 210 MOTOR WITH HIGH PRESSURE LIP SEAL		64.15
	RK-BAC-75-HYD-300-L	REPAIR KIT FOR 310-L MOTOR, EFFECTIVE 04/01		101.20



BAC-75-HYD-204 MOTOR BAC 75-HYD 206 MOTOR AND BAC-75-HYD-210 MOTOR

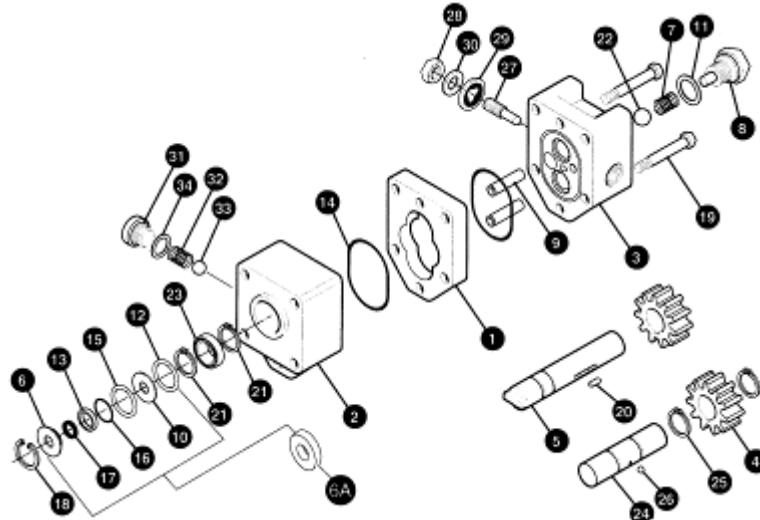

SEAL CARTRIDGE FACTORY INSTALLED ON SERIES L MOTORS

ITEM	204 MOTOR PART NO.	206 MOTOR PART NO.	210 MOTOR PART NO.	DESCRIPTION	REQ' D	204 MOTOR PRICE	206 MOTOR PRICE	210 MOTOR PRICE
1	41720	41721	41725	GEAR HOUSING	1	172.00	172.00	182.00
2	41731	41731	41731	DRIVE PLATE	1	323.00	323.00	323.00
3	41740	41740	41740	END PLATE	1	293.00	293.00	293.00
4	41750	41751	41755	GEAR	2	116.00	116.00	126.00
5	41761	41764	41766	DRIVE SHAFT	1	106.00	116.00	12600
6	41770	41770	41770	STEEL SEAL RETAINER	1	25.00	25.00	25.00
+6A	40153	40153	40153	SEAL CARTRIDGE (REPLACES#6,10,12,13,15,16,17)	1	50.00	50.00	50.00
7	41780	41780	41780	SPRING, REVERSE FLOW CHECK	1	2.05	2.05	2.05
8	41790	41790	41790	VALVE CAP, REVERSE FLOW CHECK	1	35.00	35.00	35.00
9	41800	41805	41805	DOWEL PIN, HOUSING	2	3.05	4.10	4.00
10	41810	41810	41810	STEEL BACK UP WASHER	1	4.00	4.00	4.10
11	41820	41820	41820	NYLON WASHER	1	2.05	2.05	2.05
12	41830	41830	41830	WIRE RING BEARING SPACER	1	3.05	3.05	3.05
13	41840	41840	41840	QUAD RING SHAFT SEAL COLLAR	1	5.25	5.25	5.25
*14+	41850	41850	41850	O'RING, HOUSING SEAL	2	2.05	2.05	2.05
*15	41860	41860	41860	O'RING, SEAL RETAINER	1	2.05	2.05	2.05
*16	41870	41870	41870	O'RING, SEAL COLLAR	1	2.05	2.05	2.05
*17	41880	41880	41880	QUAD RING SHAFT SEAL	1	6.10	6.10	6.10
18	41890	41890	41890	SHAFT SEAL RETAINING RING	1	1.00	1.00	1.00
19	41900	41900	41905	1/4" HEX HD CAP SCREW	4	2.05	2.05	2.05
20	41920	41921	41925	DOWEL PIN, DRIVE SHAFT	1	2.05	2.05	2.05
21	41941	41941	41941	SNAP RING, BEARING	2	0.80	0.80	0.80
22	41950	41950	41950	BALL, REVERSE FLOW CHECK	1	1.05	1.05	1.05
23	41961	41961	41961	BALL BEARING 7/16" I.D.	1	45.00	45.00	45.00
24	41970	41971	41975	IDLER SHAFT	1	56.00	56.00	56.00
25	41980	41980	41980	RETAINING RING, IDLER GEAR	2	2.05	2.05	2.05
26	41990	41990	41990	BALL, IDLER SHAFT	1	2.05	2.05	2.05
27	42010	42010	42010	NEEDLE VALVE ADJUSTING SCREW	1	25.00	25.00	25.00
28	40960	40960	40960	3/8" N.C. JAM NUT, NEEDLE VALVE	1	0.55	0.55	0.55
*29+	42030	42030	42030	#7500 3/8" N.C. THREAD SEAL	1	8.00	8.00	8.00
30	42040	42040	42040	FLAT STEEL BACKUP WASHER, NEEDLE WASHER	1	3.05	3.05	3.05
31	42041	42041	42041	VALVE CAP, COASTING CHECK	1	20.00	20.00	20.00
32	42042	42042	42042	SPRING, COASTING CHECK	1	2.05	2.05	2.05
33	42043	42043	42043	BALL, COASTING CHECK	1	2.05	2.05	2.05
*34+	42044	42044	42044	O'RING, COASTING CHECK	1	2.05	2.05	2.05
-				REPAIR KIT, RK-BAC-75-HYD FITS OLD MOTOR ONLY (PRIOR TO JUNE 2000)		101.20	101.20	101.20
+				REPAIR KIT, RK-BAC-75-HYD-L FITS OLD & NEW MOTORS(SEE NOTE)		64.15	64.15	64.15

NOTE: S200 - HYDRAULIC MOTOR SEAL SUPPORT SPACER. SPACER PROVIDES ADDITIONAL SUPPORT FOR THE CARTRIDGE TYPE (L) HYDRAULIC MOTOR SEAL. THE SPACER IS NOT FOR USE ON MOTORS EQUIPPED WITH THE QUAD RING SHAFT SEAL. THIS SPACER WORKS WITH RK-BAC-75-HYD-L REPAIR KIT.



FMC-150-HYD-206

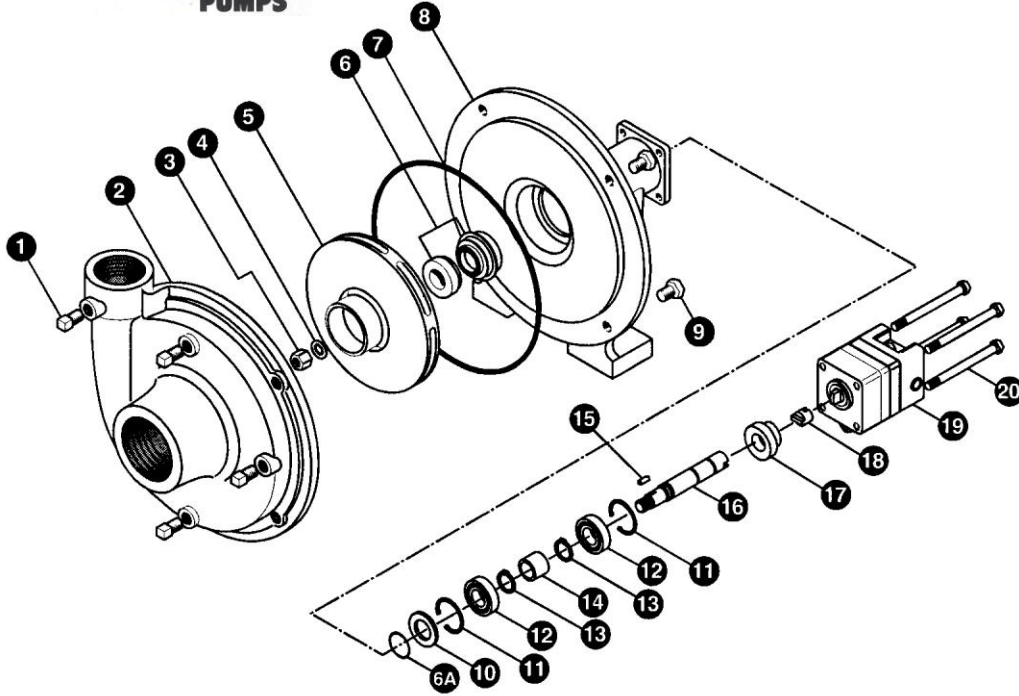

ITEM	PART NO.	DESCRIPTION	REQ'D	PRICE
1	BAC-53	PIPE PLUG	4	0.51
2	BAC-12-150	VOLUTE, 1-1/2" X 1-1/4"	1	316.00
3	BAC-23-A	NUT, 3/8" NF, CAD PLATED	1	2.55
4	BAC-24-HYD-SS	WASHER, 3/8" STAR, STAINLESS STEEL	1	1.55
5	BAC-26-150-P	IMPELLER, VALOX, KEYWAY	1	92.00
	BAC-26-150-CI	IMPELLER, CAST IRON, KEYWAY, (OPTIONAL)	1	220.00
*6	BAC-7V	SEAL, MECHANICAL, VITON(INCLUDES 40160 O'RING)	1	51.00
	BAC-7SC	SEAL, MECHANICAL, SILICON CARBIDE(INCLUDES 40160 O'RING)	1	17300
6A	40160	O'RING, SHAFT SEAL	1	1.00
*7	BAC-4-150	O'RING, BODY SEAL	1	8.15
8	BAC-14-150-HYD	MOUNTING FRAME	1	393.00
9	40950	CAP SCREW, 3/8" NC X 3/4" HEX HEAD	4	0.55
10	BAC-54	SLINGER	1	1.55
11	BAC-33	SNAG RING, INTERNAL, BAC-14 MOUNTING FRAME	2	2.05
12	BAC-37	BALL BEARING, SEALED, BAC-6 SHAFT	2	20.00
13	BAC-32	SNAP RING, EXTERNAL, BAC-6 SHAFT	2	0.55
14	BAC-32-S	SPACER FOR BAC-6 SHAFT	1	6.10
15	BACH-25	KEY, 1/8" X 1/8" X 1/2"	1	1.05
16	BAC-6-HYD-SS	SHAFT, 5/8" DIAMETER, KEYWAY AND TANG SLOT	1	128.00
17	S200	SEAL SUPPORT SPACER FOR 200 SERIES HYD MOTOR, EFFECTIVE 6/00	1	10.00
18	BAC-76-HYD	COUPLING FOR HYDRAULIC MOTOR	1	29.00
19	BAC-75-HYD-206	HYDRAULIC MOTOR, 7 GPM	1	632.00
	RK-FMC-150	REPAIR KIT FOR FMC-150 SERIES		60.70
	RK-BAC-75-HYD	REPAIR KIT FOR 206 MOTOR		101.20
	RK-BAC-75-HYD-L	REPAIR KIT FOR 200-L SERIES MOTOR		101.20
				*ITEMS INCLUDED IN PUMP REPAIR KIT



GE-75 AND 85

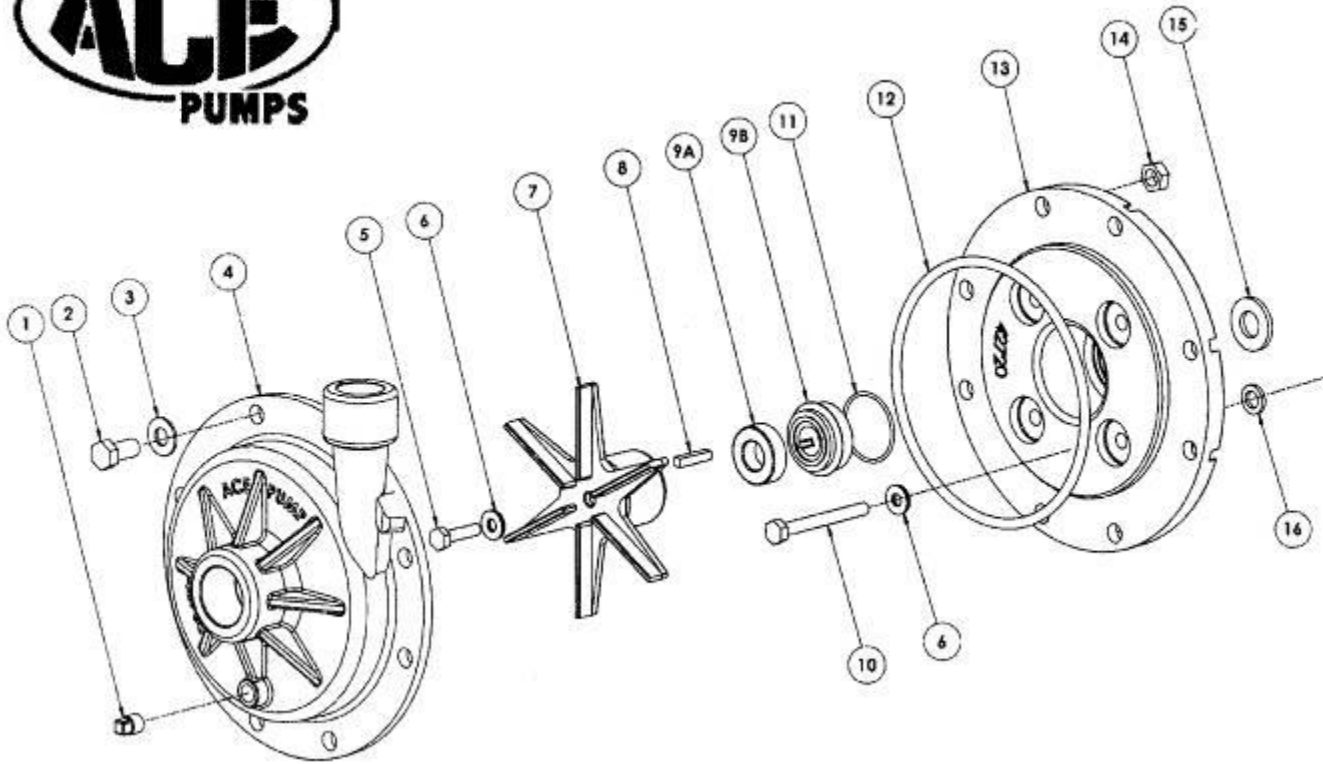

ITEM	PART NO. GE-75	PART NO. GE-85	DESCRIPTION	REQD	PRICE
1	BAC-53-P	BAC-53-P	PIPE PLUG, 1/8" NPT, PLASTIC	1	1.05
2	80250	80250	CAP SCREW, HEX HEAD	8	2.05
3	42701	42701	WASHER, FLAT	8	0.55
4	GE-12-75	GE-12-75	VOLUTE, POLY	1	128.00
5	42240	GE-60-SS	CAP SCREW, HEX, SS	1	3.05/1.55
6* ## +	30028	30028	WASHER, SEALING	5	2.05
7	GE-26-75	GE-26-85	IMPELLER, WITH KEYWAY, POLY	1	60.00/60.00
8	41082	41082	KEY	1	1.05
9*	GE-7-V	BAC-7-660V##	SEAL, VITON TYPE TUBBER	1	77.00/61.00
		BAC-7SC-660V+	SEAL, CARBIDE/CERAMIC/VITON		194.00
10	42245	42245	CAP SCREW, SS(HONDA)	4	4.10
	42238	42238	CAP SCREW, (BRIGGS)		2.80
11* ## +	40159	40159	O'RING, SHAFT SEAL, GE-75	1	1.00
12* ## +	40017	40017	O'RING, VOLUTE SEAL, GE-75	1	14.00
13	GE-14-75	GE-14-85	BRACKET, GE-75, POLY	1	133.00/13300
14	BAC-45	BAC-45	NUT	8	.50
15	BAC-54	GE-54-660	SLINGER	1	1.55/6.10
	RK-GE-75		REPAIR KIT/GE-75 *ITEMS INCLUDED IN KIT		70.25
	RK-GE-85		REPAIR KIT/GE-85 ##ITEMS INCLUDED IN KIT		86.25
	RK-GESC-85		REPAIR KIT/GE-85 +ITEMS INCLUDED IN KIT		219.25



GE-660

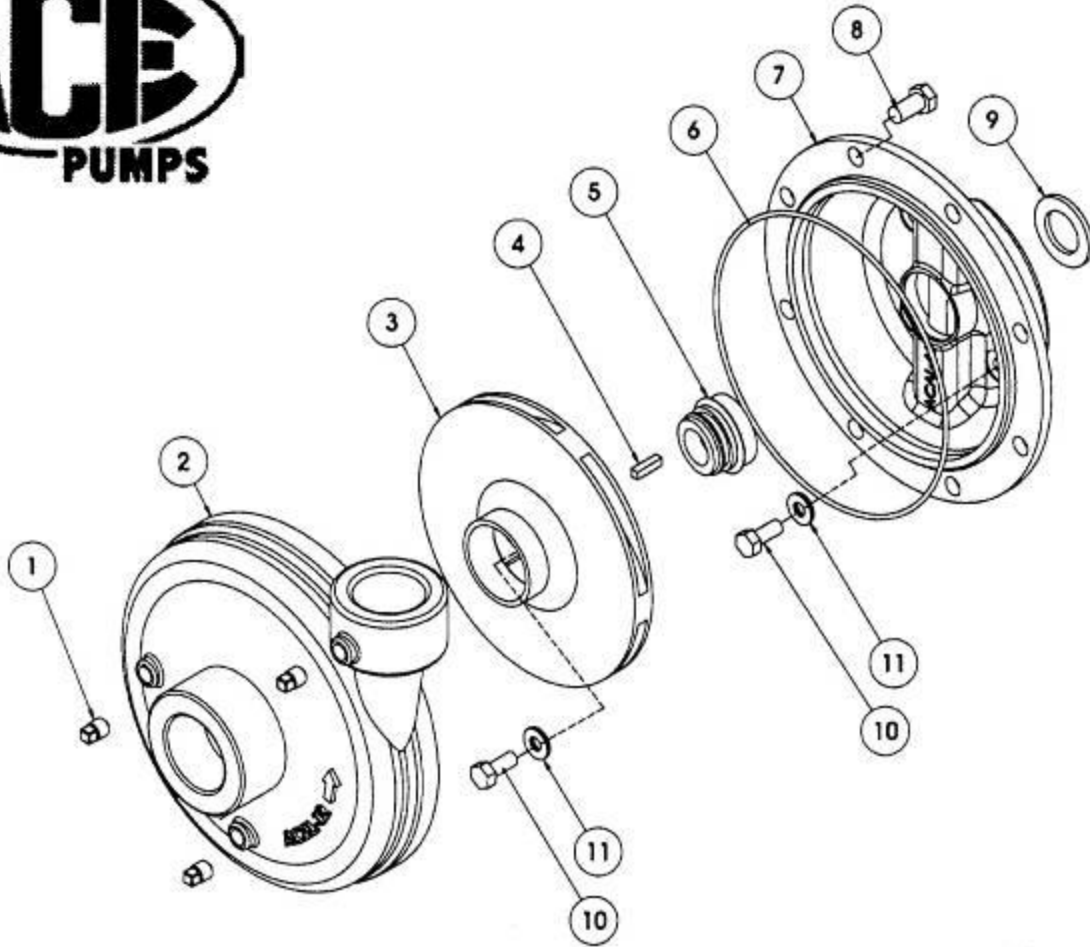

ITEM	PART NO.	DESCRIPTION	REQD	PRICE
1	BAC-53 41120	PIPE PLUG, 1/8" NPT PIPE PLUG, SS	3	0.51 5.10
2	ACAL-12	VOLUTE, CLOCKWISE ROTATION	1	321.00
3	ACAL-28-660	IMPELLER, CAST IRON, 3/4" KEYED SHAFT	1	326.00
4	41081	KEY, IMPELLER	1	1.05
5**	BAC-7-660V	SEAL, CARBON/CERAMIC/VITON	1	61.00
##	BAC-7SC-660V	SEAL, SILICON CARBIDE/VITON		194.00
6** ##	BAC-4-150	O'RING, VOLUTE SEAL	1	8.15
7	ACAL-66	BRACKET, GE-660 KEYED SHAFT	1	311.00
8	40950 40930	CAP SCREW CAP SCREW, SS	8	0.55 2.55
9	GE-54-660	SLINGER	1	6.10
10	GE-60-SS	CAP SCREW, SS	5	1.55
11** ##	30028	WASHER, SEALING	5	2.05
	RK-GE-660	REPAIR KIT **PARTS INCLUDED IN KIT		79.40
	RK-GESC-660	REPAIR KIT ##PARTS INCLUDED IN KIT		212.40



200P POLYPROPYLENE PUMP

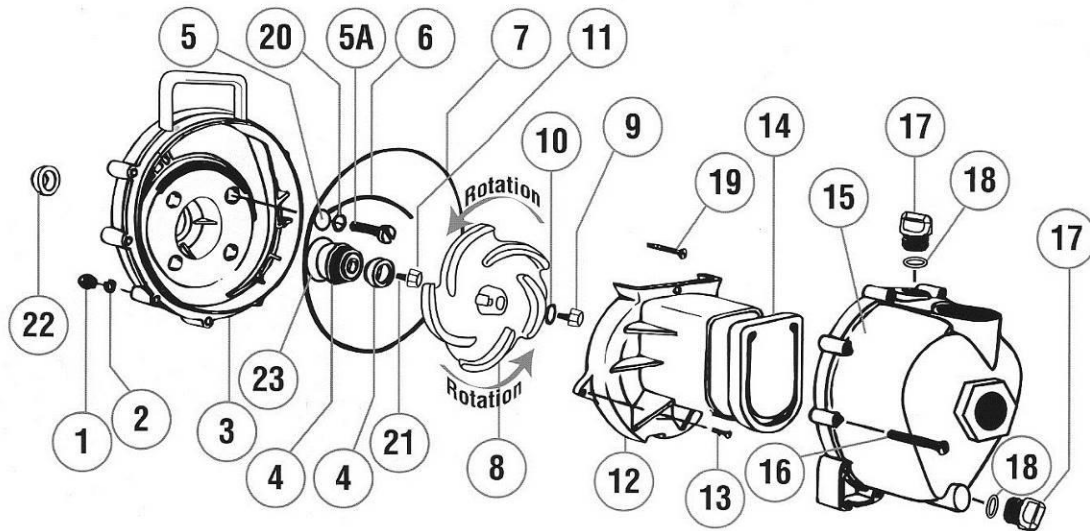

ITEM	PART NO.	DESCRIPTION	REQ'D	PRICE
200 P				
1	V07019	BODY NUTS SS	10	1.20
2	V07018	LOCK WASHER	10	1.20
3	12703A	POLY PUMP REAR BRACKET	1	103.95
4	12713	SEAL ASSEMBLY	1	50.89
5	12717	SCREW HEADS "O" RING	4	1.08
5A	12715A	BRACKET SCREWS SS	4	4.39
6	12754	"O" RING SEGMENT	1	6.97
7	12719A	BODY "O"RING	1	16.60
8	12772	5 VANE POLY PUMP IMPELLER	1	48.75
9	12765A	IMPELLER BOLT SS	1	20.90
10	12774VA	IMPELLER BOLT GASKET	1	1.89
11	12775A	IMPELLER HEX NUT	1	16.60
12	12702A	POLY PUMP VOLUTE	1	78.23
13	12725	VOLUTE SCREWS SS	2	4.39
14	12705	POLY PUMP CHECK VALVE	1	18.75
15	12712A	POLY PUMP BODY ASSEMBLY	1	160.74
16	12720	BODY SCREWS SS	10	4.39
17	12777	PRIME/DRAIN PLUG	2	3.28
18	UV15163	PRIME/DRAIN PLUG "O" RING	2	1.20
19	12900	UPPER VOLUTE SCREW SS	1	1.82
20	12901	REAR BRACKET WASHER SS	4	1.08
21	12902A	IMPELLER KEY	1	2.12
22	12716	POLY PUMP SLINGER	1	6.97
23	12710	"O" RING FOR SEAL ASSEMBLY	1	4.39
NS	12882A	COMPLETE BEARING PEDESTAL	1	246.45
NS	12099	IMPELLER REMOVAL BOLT	1	4.39
NS	12000A	PUMP REPAIR KIT-5 VANE IMPELLER (ITEMS 4-8,10,14,18,22,23 & 12099)	1	118.66
NS	12999A	PUMP SEAL O-RING KIT (ITEMS 4-7, 10, 18, 22, 23 & 12099)	1	84.65



200POI PUMP (PUMP ONLY)

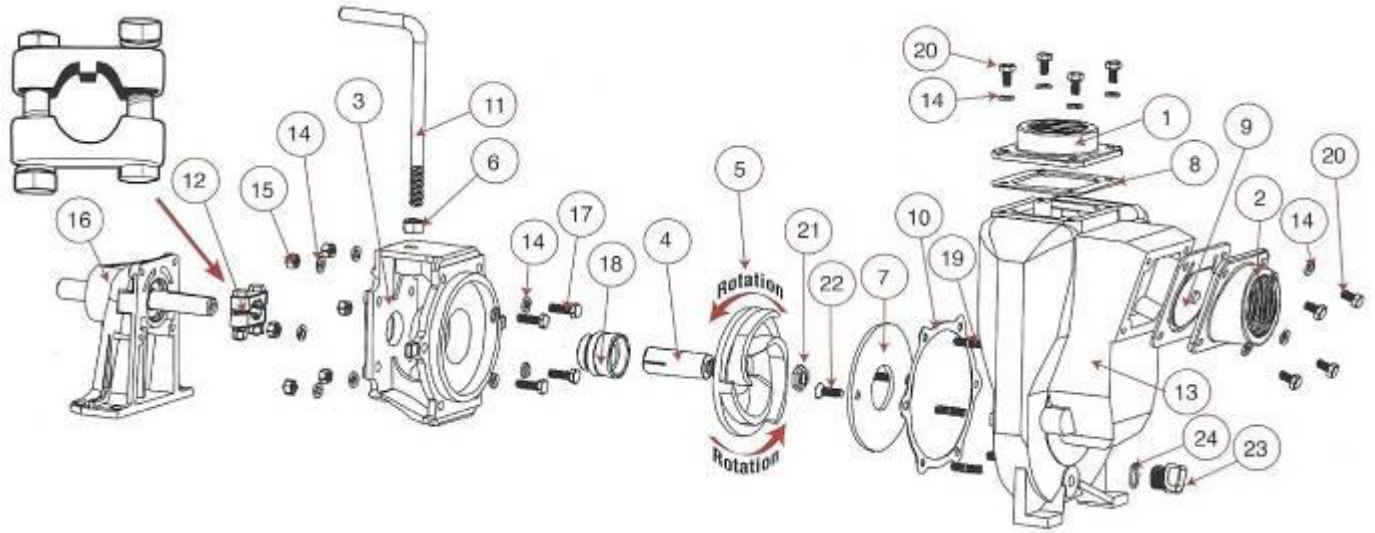

ITEM	PART NO.	DESCRIPTION	REQ'D	PRICE
1	17000	FLANGE-OUTLET THREADED 2"	1	35.64
2	17002	FLANGE-INLET 20 DEGREES 2"	1	50.43
	17003	FLANGE-INLET 20 DEGREES 1 1/2"	1	34.13
3	17004	ADAPTER-GAS ENGINE	1	117.49
*4	17005	SLEEVE-DRIVE 5/8" FOR ELECTRIC MOTOR	1	134.49
	*17006	SLEEVE-DRIVE 3/4" FOR GAS ENGINE	1	111.89
	17007	SLEEVE-DRIVE 7/8" FOR ELECTRIC MOTOR	1	111.89
*5	*17008	IMPELLER-5"(STANDARD)	1	
	17008-4.6	IMPELLER-4.6"(TRIMMED)	1	87.28
	17008-4.1	IMPELLER-4.1"(TRIMMED)	1	
6	17010	NUT, HEX 1/2" - 13 UNF-RH	1	1.57
*7	17011	WEAR PLATE	1	45.32
8	17013	EPDM GASKET	1	8.38
9	17016	GASKET-CHECKVALVE ASSY.	1	22.94
*10	17018	GASKET-ADAPTER	1	8.38
11	15022	HANDLE	1	16.23
12	17023	CLAMP 5/8", 3/4" SHAFT ASSY.(OLD STYLE)	1	52.04
	17024	CLAMP 7/8" SHAFT ASSY.	1	62.54
	17123	CLAMP 5/8", 3/4" SHAFT ASSY.(KEYED)	1	
13	17026	PUMP HOUSING	1	279.73
14	V10118	5/16" LOCKWASHER	18	1.20
15	V10119	5/16" - 18 HEX NUT SS	6	1.20

ITEM	PART NO.	DESCRIPTION	REQ'D	PRICE
N/S	12882R	HOUSING FOR BEARING PEDESTAL	1	117.87
N/S	12883R	BEARING PEDESTAL 3/4" SHAFT ONLY	1	117.87
N/S	12884	INTERNAL RETAINING CLIP FOR PEDESTAL	1	4.39
N/S	12883B	PEDESTAL BEARING	2	63.23
16	12882A	COMPLETE PEDESTAL ASSY.	1	246.45
17	17040	CAP SCREW 5/16" - 24 X 1.00" NF	4	4.59
18	17028	SEAL ASSY. (EPDM)	1	85.04
*18	17035	SEAL ASSY.(VITON TYPE)	1	85.04
18	17035SD	SEVERE DUTY SEAL	1	458.77
19	17042	STUD	6	2.46
20	17019	CAPSCREW 5/16" - 18 X 3/4"	8	1.57
21	17009B	NUT, HEX 1/2" - 13 UNC	1	11.69
22	17130	C' SINK FLAT HEAD SCREW	2	3.02
23	12777	1/2" PLUG	1	3.28
24	UV15163	O-RING	1	1.20
N/S	17032	1/4" DRAIN PLUG	1	2.57
N/S	17033	Z RAILS	PAIR	50.43
N/S	17100	PUMP REPAIR KIT (1 1/2" & 2") (CONSISTS OF ITEMS MARKED*)	1	279.73

N/S NOT SHOWN

YETTER

LIQUID FERTILIZER KIT FOR 2930

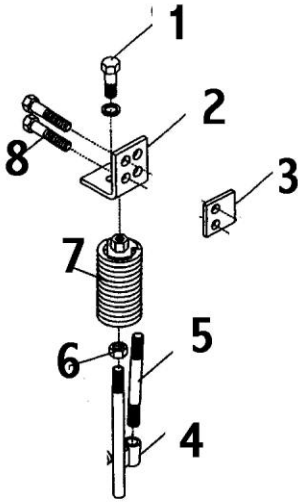

ITEM	PART NO.	DESCRIPTION	QTY	PRICE
1	2502-292	1/2-13 X 1 HHCS GR. 5 ZP		.046
2	2995-301	INJECTOR MOUNT PLATE	1	8.16
3	2995-320	SPACER, INJECTOR	1	5.27
4	2995-212	INJECTOR ROD W.A. 1/2-13	1	12.64
5	2515-311	3" NIPPLE, 1/4 NPT SS	1	10.00
6	2520-356	1/2-13 JAM NEX NUT	1	0.14
7	2995-131	INJECTOR SPRING ASSY	1	29.40
8	2502-317	1/2-3 X 1-3/4 HHCS GR.5 ZP	2	0.77

RESIDUE MANAGER WHEEL ASSEMBLY

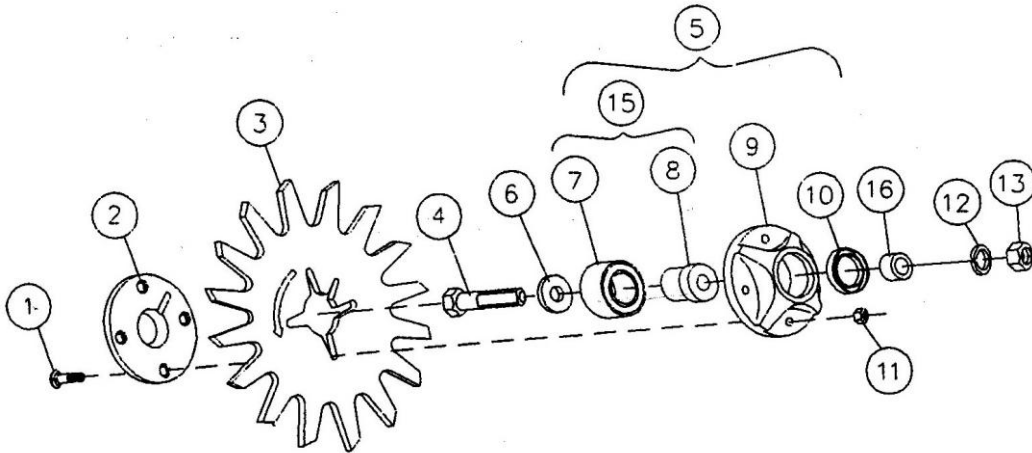

ITEM	PART NO.	DESCRIPTION	QTY	PRICE
1	2505-208	5/16-18 X 1-1/2" CAR. BLT. GR. 5 ZP	4	0.46
2	2965-352	HUB CAP CASTING, 4 BOLT, BLACK	1	8.14
3	2967-404	13" TAPER TOOTH SPOKE WHEEL	1	45.71
3A	2967-602	13" SHARK TOOTH WHEEL(NOT SHOWN)	1	56.70
4	2570-742	5/8-11 X 4" 'D' BOLT (RESIDUE MANAGER ONLY)	1	5.86
4A	2570-740	5/8-11 X 3" 'D' BOLT (FITS COMBO UNIT ONLY-)	1	5.03
5	2965-128	HUB AND BEARING ASSY, 4 BOLT INCLUDES #9,10,14 & 15	1	70.03
6	2527-530	1 1/2 O.D. X 21/32 I.D. X 3/16 THK. MACH. BUSH.	1	1.87
7	2570-594	BEARING, 2 ROW	1	26.01
8	2570-715	BEARING INSERT, TRASHMASTER	1	4.94
9	2965-351	HUB CASTING, MACHINED, 4 BOLT	1	25.59
10	2550-069	SEAL	1	5.46
11	2520-205	5/16-18 LOCK HEX NUT ZP	4	0.07
12	2525-451	5/8 MED. LOCKWASHER ZP	1	0.11
13	2520-452	5/8-11 HEX NUT ZP	1	0.34
14	2533-110	1/4" SELF TAP GREASE ZERK(NOT SHOWN)	1	0.77
16	2967-302	SPACER, ZP	1	3.53

YETTER

2910 SERIES SPRING CUSHIONED PLOW COULTER

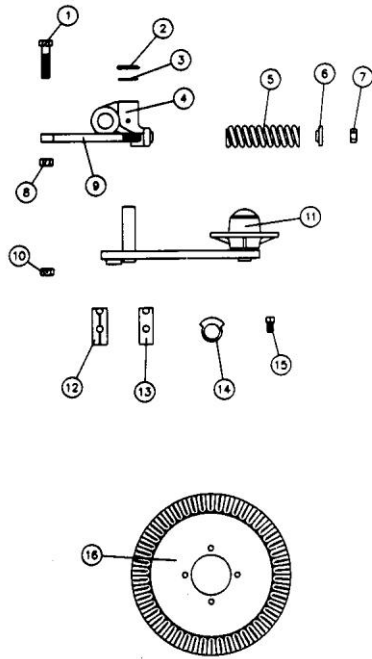

ITEM	PART NO.	DESCRIPTION	QTY	PRICE
1	2502-410	3/4"-16X3" HHCS GR 5 ZP	1	4.34
2	2531-125	1/4 X 1-3/4" COTTER KEY ZP	1	0.18
3	2526-561	1-17/64" ID X 1-7/8" OD X 14 GA MACHINERY BUSHING	1	0.68
	2900-108	COULTER SPINDLE(NOT SHOWN)	1	17.30
4	2910-320	HINGE CASTING	1	44.99
5	2910-311	SPRING	1	17.83
6	2910-302	SPRING BUSHING	1	6.13
7	2520-516	3/4"-10 HEX LOCKNUT ZP	1	0.83
8	2520-508	3/4-16 HEX NUT ZP	1	0.62
9	2570-125	PUSH ROD	1	14.43
10	2520-511	3/4-16 LOCK HEX NUT ZP	1	0.94
11	2910-201	COULTER ARM W.A.	1	60.69
12	2910-127	NLA		
		NLA		
13	2910-301	LOCKING COLLAR	1	9.64
14	2503-379	5/8"-11 X 1 SQ. HCPSS	1	1.13
1	2571-076	20" RIPPLE BLADE(8 HOLE)	OPT	55.00
	2571-077	17" RIPPLE BLADE(8 HOLE)	OPT	49.00
NS	2530-208	ROLL PIN - 3/8 X 2 1/2		1.55

2910 AND 2900 SERIES HUB ASSEMBLY

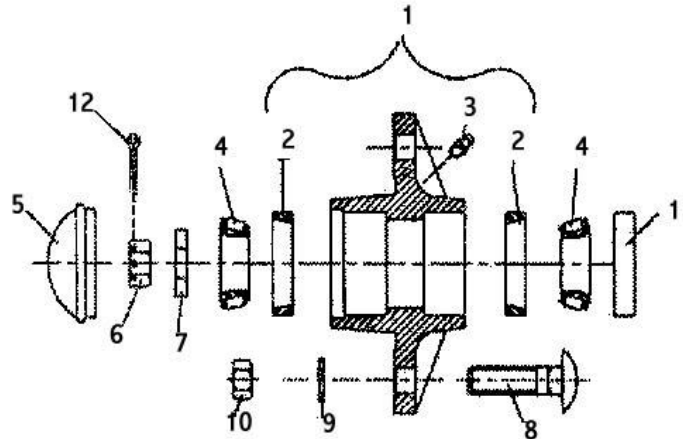

ITEM	PART NO.	DESCRIPTION	QTY	PRICE
1	2900-105	HUB PRESSED ASSEMBLY WITH CUPS	1	40.13
2	LM-67010	~CUP PRE-ASSEMBLED W. NO.1	REF.	4.51
3	2533-110	1/4-28 ZERK STRAIGHT SELF-TAP(PRE-ASSEMBLED W#1)	REF.	0.77
4	LM-67048	CONE	2	9.52
5	2570-375	HUB CAP	1	6.59
6	2520-469	5/8" FLATWASHER 1/4" THK.	1	2.77
7	2526-449	5/8" FLATWASHER, 1/4" THICK	1	1.06
8	2505-337	1/2-13 X 1 1/2 CARRIAGE BOLT GRADE 5 ZYD	4	1.02
9	2525-352	1/2 MED LOCKWASHER ZYD	4	0.18
10	2520-352	1/2-13 HEX NUT ZYD	4	0.13
11	2550-066	SEAL	1	4.60
12	2531-102	1/8 X 1/4 COTTER PIN	1	0.46
		2900-123 HUB ASSEMBLY (INCLUDES 1 - 11)		74.70

YETTER

2996 SERIES 20" FERTILIZER COULTER ASSEMBLY

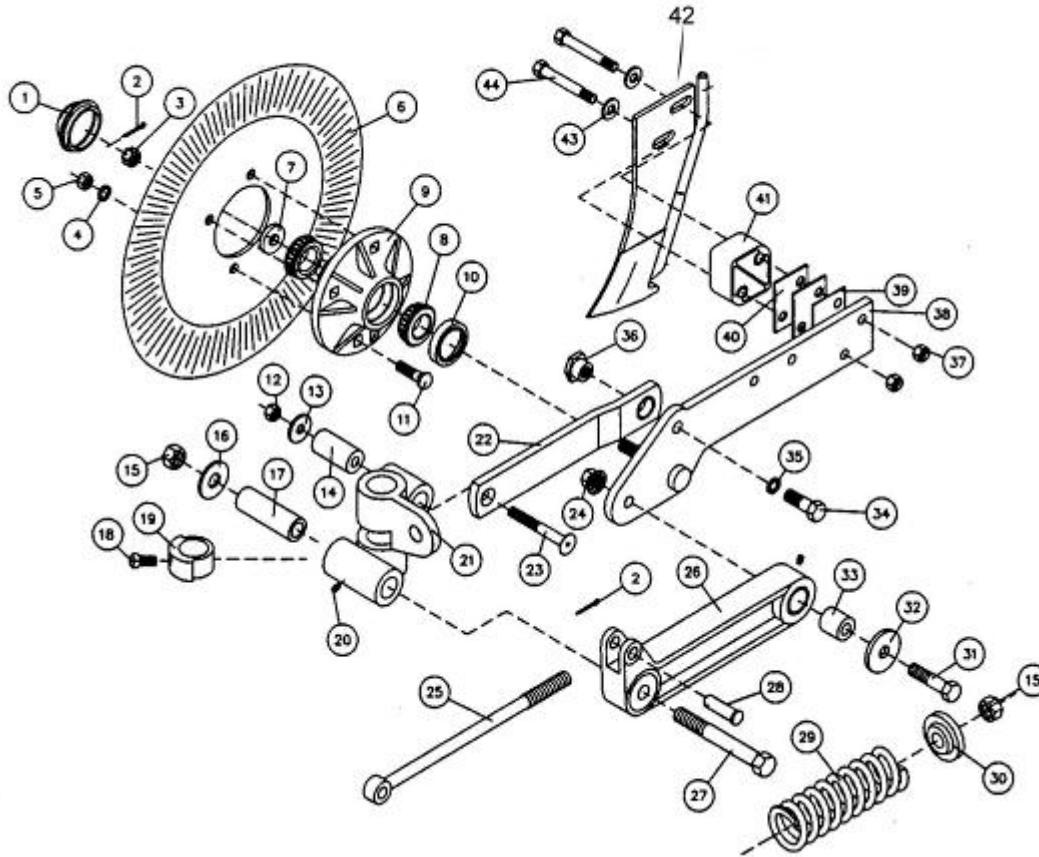

ITEM	PART NO.	DESCRIPTION	PRICE
1	2570-375	HUB CAP	6.59
2	2531-102	1/8 X 1 1/4" COTTER PIN	0.46
3	2520-469	5/8-18 SLOTTED HEX NUT	2.77
4	2525-352	1/2 LOCKWASHER, 4 REQD	0.18
5	2520-352	1/2-13 HEX NUT 4 REQD	0.13
6	2571-168	20" RIPPLE BLADE	57.00
7	2526-449	5/8 FLATWASHER	1.06
8	LM-67048	CONE, 2 REQD	9.50
9	2900-105	HUB PRESSED ASSY	40.13
10	2550-066	SEAL, CR#16069	4.60
11	2505-339	1/2-13 X 1 1/2" CAR BLT 4 REQD	0.81
12	2520-357	1/2-13 LOCK HEX NUT	0.46
13	2527-340	1/2X 1 1/2 X 10 GA MA BU	1.11
14	2995-303	PIVOT SLEEVE	11.99
15	2520-515	3/4-10 LOCK HEX NUT 2 REQD	1.10
16	2527-529	25/32 X 2 X 10 GA MA BU	2.87
17	2570-704	PIVOT SLEEVE	10.41
18	2503-379	5/8-11 X 1 SQ HCPSS	1.16
19	2975-303	2975 LOCKING COLLAR	11.12
20	2533-110	1/4-28 ZERK SELF TAP 3 REQD	0.77
21	2995-307	COULTER PIVOT RH(SHOWN)	90.42
	2995-306	COULTER PIVOT,LH	
22	2995-111	UPPER COULTER ARM ASSY	17.67
23	2502-360	1/2-13 X 4 HSFHCS	4.41
24	2520-464	5/8-11 WHIZLOCK HEX NUT	1.38

ITEM	PART NO.	DESCRIPTION	PRICE
25	2995-304	SPRING ROD	18.42
26	2995-110	LOWER COULTER ARM ASSY	89.11
27	2502-510	3/4-10 X 6 HHCS	4.56
28	2995-308	SPRING ROD PIN	4.02
29	2550-795	SPRING 11" LONG	50.21
30		NLA	
31	2502-393	5/8-11 X 2 1/2 HHCS	1.72
32	2527-529	21/32 X 2 1/4X 1/4 MA BU	2.87
33	2570-761	LOWER ARM PIVOT	7.76
34	2502-339	5/8-18 X 1 1/2 HHCS	1.28
35	2525-451	5/8 MED LOCKWASHER	0.11
36	2570-762	UPPER ARM PIVOT/WASHER	9.43
37	2520-362	1/2-13 HEX NIF-LOK NUT (2 REQD)	0.41
38	2996-205	RH KNIFE ARM/SPINDLE	56.95
		WA(SHOWN)	
	2996-204	LH KNIFE ARM/SPINDLE WA	56.95
39	2970-320	KNIFE SHIM, 16 GA	3.36
40	2970-319	KNIFE SHIM, 1/8	3.75
41	2995-309	SPACER BLOCK	23.11
42	2996-200	20" LIQUID FERTILIZER KNIFE	61.80
		WA	
43	2526-355	1/2 FLAT WASHER (2 REQD)	0.23
44	2502-358	1/2-13X3 1/2 HHCS (2 REQD) L	2.45
	2530-208	3/8 X 2 1/2 ROLL PIN ZP	1.55
	2531-161	5/16 X 2 1/2 COTTER PIN ZP	0.64

2968-020 ROW UNIT

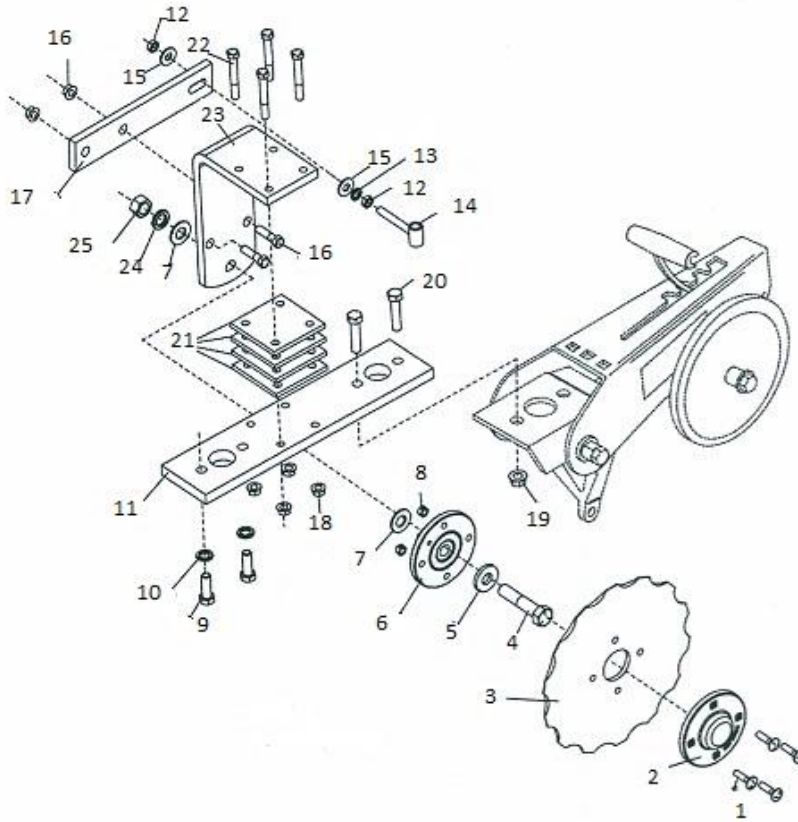

ITEM	PART NO.	DESCRIPTION	QTY	PRICE
1	2505-207	5/16-18 X 1-1/4 CAR BOLT GR 5	4	
2	2965-352	HUB CAP CASTING, 4 BOLT, BLACK	1	8.14
3	2968-320	10.05 X .256 FERTILIZER WHEEL	1	58.39
4	2570-740	5/8-XX X 3" D BOLT GR 5	1	5.03
5	2527-530	1.5 OD X 21-32 ID 3/16 THK MA BUSH	1	1.87
6	2965-128	HUB & BEARING ASSY, 4 BOLT 2550-052 SEAL 2570-594 BEARING 2570-715 INSERT 2965-351 HUB 2533-110 ZERK	1	70.03
7	2526-454	5/8 SAE FLATWASHER HARD'ND	2	1.47
8	2520-205	5/16-18 LOCK HEX NUT ZP	4	0.07
9	2502-379	M12 X 1.75 X 35 GRD 10.9	2	1.96
10	2525-352	1/2 MED LOCK WASHER ZP	2	0.18
11	2968-325	CLOSE WHEEL RELOCATION PLATE	1	46.04
12	2520-253	3/8-16 JAM HEX NUT ZP	2	0.06
13	2525-251	3/8 MED LOCKWASHER ZP	1	0.29
14	2968-218	INJECTOR HOLDER WA	1	13.11
15	2526-251	3/8 STANDARD FLATWASHER ZP	1	0.55
16	2502-232	3/8-16 X 1 1/2 HHCS GR 5 ZYD	2	0.44
17	2968-351	INJECTOR BRACKET	1	8.10
18	2520-258	3/8-16 HEX FLANGE LCK NUT ZP	6	0.14
19	2520-307	7-16-14 FLANGE WHZLOCK HXN	2	0.56
20	2502-267	7/16-14 X 2 HHCS GR 5 ZYD	2	0.64
21	2968-326	1/4 SHIM PLATE	4	11.27
22	2502-241	3/8-16 X 2 3/4 HHCS GR 5 ZP	4	0.50
23	2968-327	FERT. WHEEL MOUNT	1	32.39
24	2525-451	5/8 MED LOCK WASHER ZP	1	0.11
25	2520-452	5/8-11 HEX NUT ZP	1	0.34

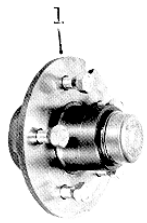

HUB ASSEMBLIES

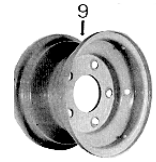
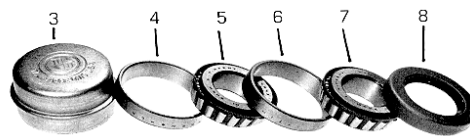
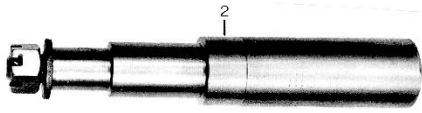

6 LUB HUB ASSY-ARMSTRONG (AR&W STAMPED ON INSIDE OF HUB)

4 LUG HUB - USED ON GAUGE WHEELS AND ATV SPRAYER

ITEM	PART NO.	DESCRIPTION	PRICE	ITEM	PART NO.	DESCRIPTION	PRICE
1	888200-6	6 LUB HUB COMPLETE W/BEARINGS & WHEEL BOLTS	65.00	1	H4-C	4 LUB HUB COMPLETE W/BEARINGS & BOLTS	45.20
1	888300-6	6 LUB HUB W/CUPS ONLY	53.00				
2	LS8131H-12	SPINDLE W/NUT & WASHER	37.25	2	SA-1250	1250 X 1" SPINDLE W/NUT	15.00
3	DC-13	DUST CAP	5.00	3	GC-1	DUST CAP	2.50
4	LM-67010	OUTER CUP	4.55	4 & 6	L44610	OUTER/INNER CUP	2.25
5	LM-67048	OUTER CONE	9.50	5 & 7	L44643	OUTER CONE	4.50
6	JL69310	INNER CUP	6.55	8	GS-2	SEAL	1.50
7	JL69349	INNER CONE	19.50				
8	CR16289	GREASE SEAL	14.15				
NS	WB10	WHEEL BOLTS	1.15	NS	WB-12	WHEEL BOLTS	1.40
				NS	BK-1	BEARING KIT	20.25

WHEELS

TIRE & WHEEL ASSY

ITEM	PART NO.	DESCRIPTION	PRICE	ITEM	PART NO.	DESCRIPTION	PRICE
9	15X6X6	6 X 6 LUG WHEEL	89.00	NS	25-10-12-KIT	ATV WHEEL/TIRE ASSY	330.00
	9.5LX15	8 PLY TIRE	272.00				
	15X8X6	8 X 6 LUG WHEEL	164.45	NS	18X8.5X8	4 BOLT GAUGE WHEEL/TIRE ASSY	108.00
	11LX15	8 PLY TIRE	280.15				
	15X10X6	10 X 6 LUG WHEEL	167.20	NS	TWA13X5-6	LAWN & GARDEN WHEEL/TIRE ASSY	39.15
	12.5LX15	8 PLY TIRE	280.00				
	17-255-7	WHEEL-1000 GAL TRAILER W/TORSION AXLE	63.50				
	LT23585R16BE-I	TIRE 1000 GAL TRAILER	359.00				
	WH175675-80E.19	WHEEL 1650 GAL TRAILER	140.00				
	235-75R-175H-I	TIRE 1650 GAL TRAILER	460.00				

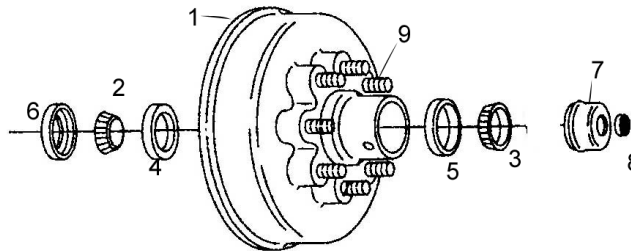

1000 GALLON NURSE TRAILER WHEEL ASSY

1635 GALLON NURSE TRAILER WHEEL ASSY

ITEM	PART NO.	DESCRIPTION	PRICE	ITEM	PART NO.	DESCRIPTION	PRICE
1	42655UC1-EZ	LUBE HUB & DRUM ASSY	67.50	1	8-285-11UC3	HUB & DRUM ASSY	400.12
2	25580	INNER BEARING	13.65	2	25580	INNER BEARING	13.65
3	15123	OUTER BEARING	8.00	3	02475	OUTER BEARING	11.15
4	25520	INNER RACE	6.30	4	25520	INNER RACE	6.30
5	15245	OUTER RACE	3.85	5	02420	OUTER RACE	7.25
6	10-36	GREASE SEAL	2.60	6	10-36	GREASE SEAL	2.60
7	21-42-1	GREASE CAP	3.15	7	21-43-1	GREASE CAP	3.25
8	85-1	GREASE CAP PLUG	1.35	8	85-1	GREASE CAP PLUG	1.35
9	7-122	DRIVE IN STUD	2.10	9	7-132	DRIVE IN STUD	2.70
10	X1023R	CONE WHEEL NUT (NS)	0.90	10	6-53	CONE WHEEL NUT (NS)	1.55

D4-C DITCHER

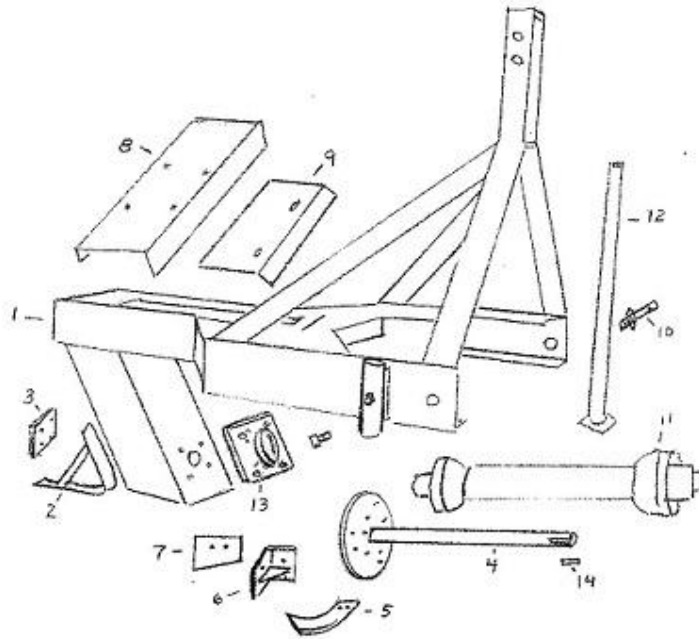

ITEM	PART NO.	DESCRIPTION	REQ'D	PRICE	
1	D4-F	MAIN FRAME	1	1672.50	
2	D4-2	REAR SLIDE ASSEMBLY	1	55.80	
3	D4-3	SLIDE CLAMP PLATE	1	22.88	
4	D4-4	ROTOR AND SHAFT	1	200.03	
5	D4-5	MAIN CUTTING BLADES	3	13.45	
6	D5-24	WIPER ANGLES	3	37.65	
7	D4-7	WIPER BLADES	3	11.43	
8	D4-8	DIRT SHIELD	1	32.85	
9	D4-9	CLUTCH SHIELD	1	17.44	
10	P728	LEFT PINS W/NUT, LOCKWASHER	2	3.33	
11	242-22559	UNIVERSAL JOINT AND TELESCOPING SHAFT ASSY	1	900.00	
12	D4-12	STAND PIPES	2	25.31	
13	D4-13	BEARING WITH HOUSING	2	29.00	
	D4-13-1	BEARING ONLY	2	15.00	
14	D4-14	DRIVE SHAFT KEY - 5/16"	1	2.15	
*NI	HC-0516-100	5/16" x 1" HEX CAPSCREW	DIRT SHIELD	10	0.18
*NI	HN-0516	5/16" HEX NUT	DIRT SHIELD	10	0.18
*NI	LW-0516	5/16" LOCKWASHER	DIRT SHIELD	10	0.13
*NI	SHSS-038-034	3/8" x 3/4" SQUARE HEAD SET SCREW	STAND PIPE	2	0.41
*NI	HC-038-100	3/8" x 1" HEX CAPSCREW GR.5	WIPER BLADES	6	0.23
*NI	HC-038-300	3/8" x 3" HEX CAPSCREW GR. 5	DRIVE SHAFT	3	0.46
*NI	HN-038	3/8" HEX NUT		9	0.18
*NI	LW-038	3/8" LOCKWASHER		7	0.13
*NI	FW-038	3/8" FLATWASHER		2	0.10
*NI	SHSS-0716-100	7/16" x 1" SQUARE HEAD SET SCREW		2	0.44
*NI	HC-FT-012X112	1/2" x 1 1/2" NF CAPSCREW GR. 5	CUTTING BLADES	6	0.64
*NI	HC-012-112	1/2" x 1 1/2" HEX CAPSCREW GR. 5	BEARINGS, WIPER, ANGLES	14	0.46
*NI	HC-012-134	1/2" x 1 3/4" HEX CAPSCREW GR. 5	SLIDE PLATE	4	0.50
*NI	HN-012	1/2" HEX NUT	SLIDE PLATES, ANGLES, BEARINGS	18	0.23
*NI	LN-FT-012	1/2" NF LOCK NUT	BLADE	6	0.64
*NI	LW-012	1/2" LOCKWASHER	SLIDE PLATE, ANGLES, BEARINGS	18	0.18
* NOT ILLUSTRATED					

NEW STYLE SHAFT & CLUTCH FOR DITCHERS AFTER JANUARY 1999

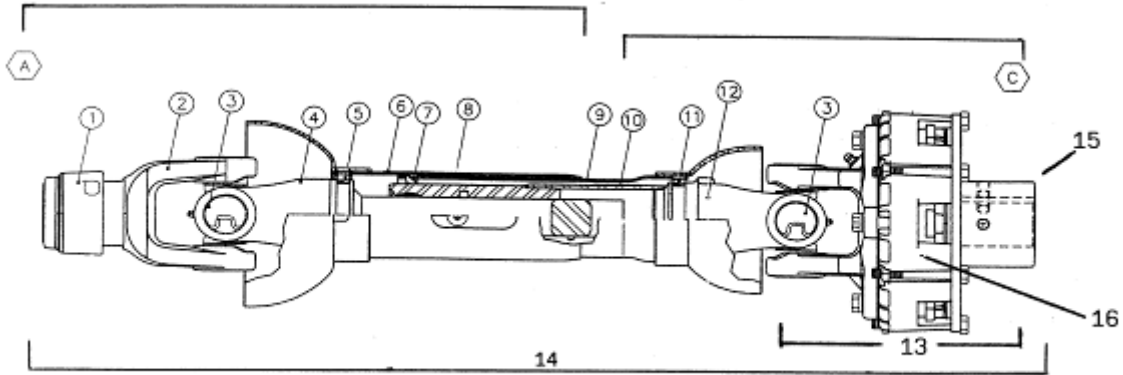

ITEM	PART NO.	DESCRIPTION	PRICE
A	83-22559	JOINT & SHAFT HALF ASSEMBLY W/GUARD SET(TRACTOR END)	700.00
C	82-22559	JOINT & TUBE HALF ASSEMBLY W/GUARD SET AND CLUTCH	730.00
1	26-15120	SAFETY SLIDE LOCK REPAIR KIT	54.50
2	35031-1015	SAFETY SLIDE LOCK YOKE ASSEMBLY	101.25
3	03-10045	35R CROSS & BEARING KIT (2 REQUIRED)	56.25
4	99-9082	YOKE & SHAFT	271.25
5	19-15126	NYLON REPAIR KIT (NEW NUMBER EFFECTIVE 6-04)	9.50
6			
7			
8&9	90-22559	COMPLETE GUARD SET	203.00
10			
11	19-11147	NYLON REPAIR KIT	10.80
12	98-9082	YOKE, TUBE, AND SLIP SLEEVE	335.70
13	38-11012	FREE MOTION FRICTION CLUTCH ASSEMBLY(INCLUDING YOKE & HUB)	795.60
14	242-22559	UNIVERSAL JOINT AND TELESCOPING SHAFT ASSY	900.00
15	38-60013	YOKE & FREE MOTION HUB	332.00
16	38-50014	FREE MOTION FRICTION CLUTCH PACK	389.50
NS	95-18955	JOINT & SHAFT HALF ASSY(TRACTOR END LESS GUARD) SAME AS ITEM A LESS GUARD	312.50
NS	94-18955	JOINT & TUBE HALF ASSY(CLUTCH END LESS GUARD) SAME AS ITEM C LESS GUARD	850.00

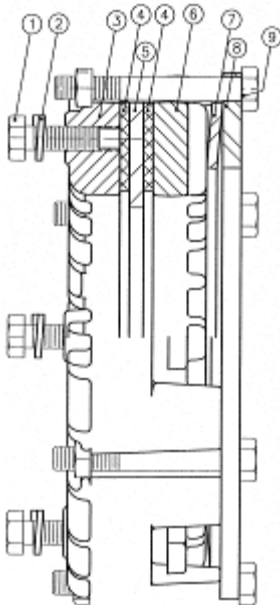

38-500114 FREE MOTION FRICTION CLUTCH PARTS LIST

ITEM	PART#	DESCRIPTION	QTY	PRICE
1	HC-0516-100	BOLT .312-18 X 1.00 LG GR 5	4	0.18
2	LW-0516	LOCK WASHER, .312	4	0.13
3	80281-1000	HOUSING	1	64.50
4	11-11167	FRICTION DISC	2	45.00
5	20-15133	SEPARATOR PLATE	1	49.45
6	80311-1000	PRESSURE PLATE	1	65.85
7	23-15039	SPRING	1	100.40
8	38-40075	COMPRESSION PLATE	1	35.10
9	HC-0516-212	BOLT .312-18 X 2.50 LG GR 5	6	0.48
10	HN-0516	NUT .312-18(NOT SHOWN)	6	0.18

D5-C

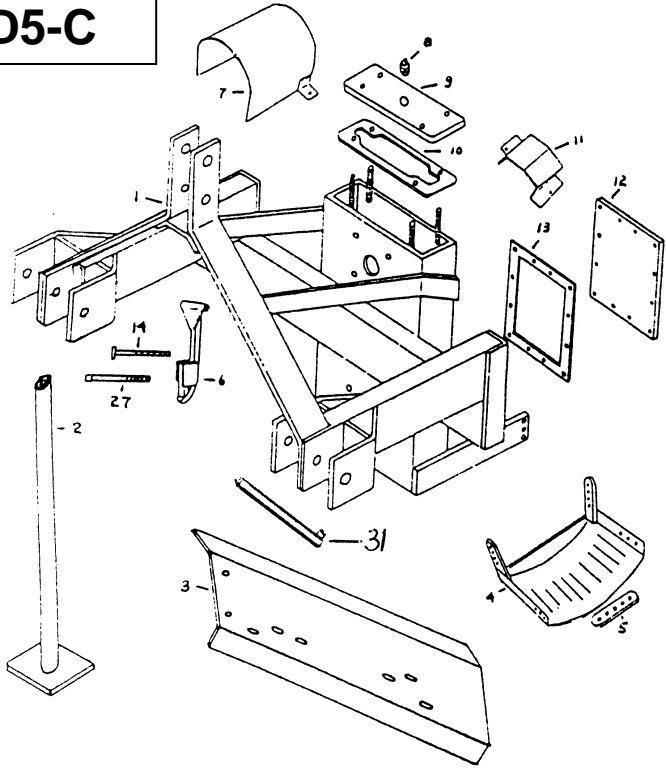

D5- REQUIRES 1 QUART
90W OIL

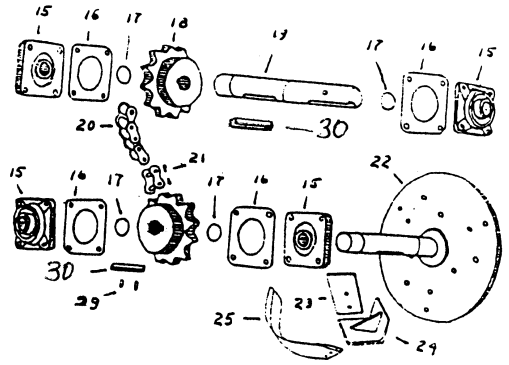

D6-OS-C

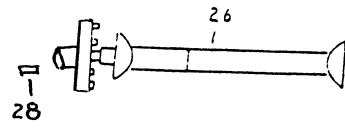
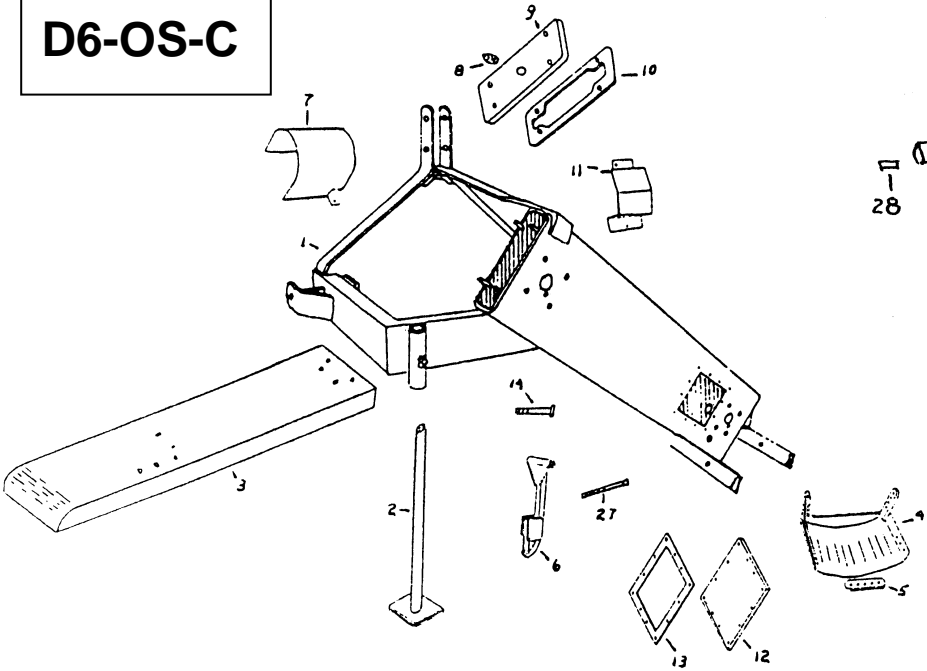

D6- REQUIRES 2 QUART
90W OIL

D5-C AND D6-OS-C DITCHER

ITEM	PART NO.	DESCRIPTION	QTY. REQ'D. D5-C	QTY. REQ'D. D6-OS-C	PRICE
1	D5-F	MAIN FRAME ASSEMBLY FOR D5-C	1	0	Obsolete
	D6-F	MAIN FRAME ASSEMBLY FOR D6-OS-C	0	1	1607.12
2	D5-2	FRAME LEGS	2	2	27.56
3	D5-3	DIRT SHIELD	1	1	80.05
	D6-3	DIRT SHIELD (D6 DITCHER)	1	1	149.06
4	D5-4	SKID ASSEMBLY	1	1	126.77
5	D5-5	REAR SKID HANGER	2	2	17.67
6	D5-6	CHAIN TIGHTENER ASSEMBLY	1	1	34.20
7	D5-7	PTO CLUTCH GUARD	1	1	31.38
8	D5-8	OIL FILL PLUG, VENTED	1	1	3.53
9	D5-9	COVER, TOP MAIN FRAME	1	1	19.35
10	D5-10	GASKET, TOP COVER	1	1	3.85
11	D5-11	REAR BEARING GUARD	2	2	18.11
12	D5-12	COVER, MAIN FRAME REAR	1	1	22.27
13	D5-13	GASKET, REAR COVER	1	1	4.50
14	D5-14	PIVOT BOLT, 7/16" x 4 1/2" NC	1	1	.86
15	D4-13	BEARING WITH HOUSING	4	4	29.00
	D4-13-1	BEARING ONLY	4	4	15.00
16	D5-16	GASKET, FLANGE BEARING	4	4	3.20
17	D5-17	O'RING, SHAFT	4	4	1.15
18	D5-18	SPROCKET, 12 TOOTH, #120, 1 7/16" BORE	2	2	99.20
19	D5-19	UPPER SHAFT	1	1	75.37
20	D5-20	CHAIN, #120, 34 PITCHES	1	2	66.40
21	D5-21	CONNECTING LINK #120	1	2	5.81
	D5-21A	OFFSET LINK #120	1	1	9.50
22	D5-22	LOWER SHAFT AND ROTOR PLATE	1	1	203.06
23	D5-23	WIPER FLAT	3	3	10.17
24	D5-24	WIPER ANGLE	3	3	37.65
25	D4-5	CUTTING BLADES	3	3	13.45
26	242-22559	UNIVERSAL JOINT AND TELESCOPING SHAFT ASSY	1	1	900.00
27	SHSS-012-412	SQ. HEAD SET SCREW, CHAIN TIGHTENER, 1/2" x 4 1/2"	1	1	3.13
28	D4-14	DRIVE SHAFT KEY 5/16"	1	1	2.15
29	D5-29	SET SCREW, 3/8" - 16 x 5/8"	2	2	0.34
30	D5-30	SPROCKET KEY 3/8"	2	2	4.81
31	P7238	LIFT PIN	2	2	11.75